

The logo for Eaze, featuring a stylized 'E' symbol followed by the lowercase letters 'eaze' in a bold, sans-serif font.

EN-IT-FR-DE-ES-PT

# Power Manager

**Installation manual**

V.5  
13/02/2025

*The information contained in this manual is the property of Daze and may not be reproduced either in part or in whole. This manual is provided to the client together with the device. Daze will not be held responsible for any damage that may directly or indirectly result to persons, property, or animals as a result of due to failure to comply with all the requirements set forth in this manual.*

This manual covers all models with the following part number:  
PM02M, PM02T, PM02T100, PM03M, PM03T30, PM03T100.

In the following languages:

**EN**

pg. 4

**IT**

pg. 18

**FR**

pg. 32

**DE**

pg. 46

**ES**

pg. 60

**PT**

pg. 74



# 01 – Introduction

The Power Manager is a device that dynamically adjusts the power allocated for vehicle charging to ensure that the contractual power limit of the meter is not exceeded, preventing blackouts caused by charging.

There are two different versions, the Power Manager for DIN rail mounting (codes: PM02M, PM02T, PM02T100 - Fig. 1A) and the compact version (codes: PM03M, PM03T30, PM03T100) for installations in confined spaces - Fig. 1B.

Dazebox C, Dazebox Home, Dazebox Share, Duo, and Urban can also operate without the Power Manager, as its installation is not mandatory. However, without the Power Manager, there is no guarantee that a blackout will be avoided if the meter's power limit, set via the app during network configuration, is exceeded.

The Power Manager consists of 2 elements:

- Control board CT box plastic
- Current sensor in single-phase version (PM02M PM03M) and three-phase 30kW version (PM02T PM03T30) in Fig. 1C and sensor for three-phase 100kW version (PM02T100 PM03T100) in Fig. 1D.

For three-phase Power Manager versions, three current sensors are provided.

Fig. 1A

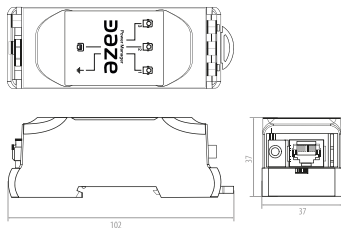


Fig. 1B

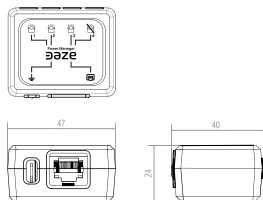


Fig. 1C

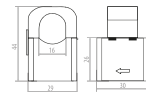
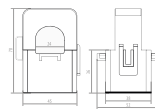


Fig. 1D



**Single-phase**

PM02M / PM03M

**three-phase**PM02T / PM02T100  
PM03T30 / PM03T100

## General Specifications

### 1 Compatible Products

Dazebox C: DB07\*\*M\* / DB07\*\*T\* / DB07\*\*M\*\*\* / DB07\*\*T\*\*\*  
 Dazebox Home: DT01\*\*32\*\* / DS01\*\*32\*\* / DK01\*\*32\*\*P / DS01\*\*32\*\*P  
 Dazebox Share: DT02\*\*32\*\* / DS02\*\*32\*\* / DK01\*\*32\*\*P / DS01\*\*32\*\*P  
 Duo: OT01\*\*64\*\*\*\* / OS01\*\*64\*\*\*\*  
 Urban: UT01IT64T\*\*\*\* / US01IT64T\*\*\*\*

## Electrical Specifications

2	Maximum power counter	12,5 kW	37,5 kW / 100 kW *
3	Maximum current for phase	55 A	55 A / 145 A

\*The 100 kW Power Manager Module is only compatible with Dazebox Home, Dazebox Share, Duo, and Urban

## Installation

4	Number of current sensors	1	3
5	Maximum phase cable section	Up to 50 mm <sup>2</sup>	Up to 50 mm <sup>2</sup> / Up to 120 mm <sup>2</sup>
6	Charger connection cable (*it is not guaranteed that cables of a higher category than Cat5e are suitable for the provided shielded RJ45 connectors)	Shielded CATe* network cable	
7	Network cable shielding	F o S/FTP - SF/FTP - SF/UTP - F/UTP	
8	Length of current sensor connection cable - CT box	900 mm	
9	Connection to CT box	Jack 3,5 mm	
10	Maximum network cable length from CT box to charger	170 m	
11	Mounting	DIN rail or screw mounting (PM) / Freestanding (Compact PM)	

## 02 – Installation



The connection of the sensor for the Load Balancing function requires installation by a professional technician.

**Note: Only one Power Manager can be installed downstream of a meter. In installations with multiple chargers, the Power Manager must be connected only to the first charger added to the network. The remaining chargers should be added to the network afterward and wired according to the scheme in Chapter 2.4.**

### 02.1 – Package contents

The package includes:

1. Current sensor (1x for single-phase version and 3x for three-phase version);
2. CT box control board;
3. Shielded RJ45 connectors with bend protection (2x).

### 02.2 – Preparation for installation

Required but not included in the package:

- Network cable for connecting the CT box to the charger.
- Faston connector (female) and cable for grounding.

## 02.3 – Mounting

1. Prepare the installation of a network cable of the type specified in the "Installation" section of Chapter "1" to connect the CT Box to the charger installation location.

2. The current sensor (A) must be positioned on the line cable (L) exiting the main meter (C) before any branching. If using a three-phase meter, place the three sensors respectively on L1, L2, and L3. Refer to the wiring diagrams on pages 22-23 to position the sensor correctly. Incorrect placement may cause malfunctions.

3. The current sensor has a jack connector (J) for connection to the CT box board (B). The board also has an RJ45 input for connecting the CT box to the charging system using a shielded Cat5e network cable.

The RJ45 connectors for wiring both cable ends are included. Crimping instructions are provided from step 5 to step 12 on the following pages. Perform grounding using a Faston connector (as shown in Fig. 2).

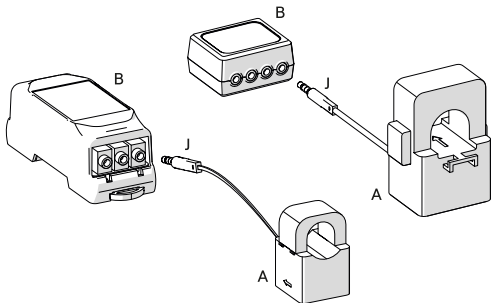
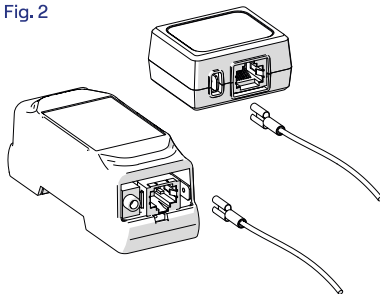


Fig. 2



## 1. Wiring diagram of PM02M in a single-phase system

C: Meter

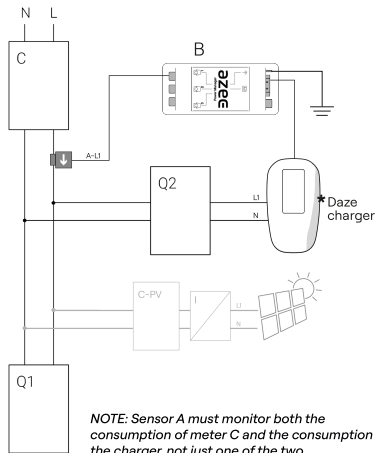
Q1, Q2, ...: electrical cabinets

B: CT box board

A-L1: current sensor

C-PV: photovoltaic meter / I: photovoltaic inverter

(if photovoltaic system is present)



## 2. Wiring diagram of PM02T/PM02T100 in a three-phase system

C: meter

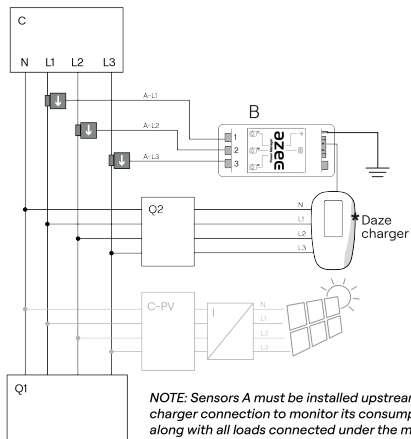
Q1, Q2, ...: electrical cabinets

B: CT box board

A-L1 / L2 / L3: current sensor

C-PV: photovoltaic meter / I: photovoltaic inverter

(if photovoltaic system is present)



### 3. Wiring diagram of PM03M in a single-phase system

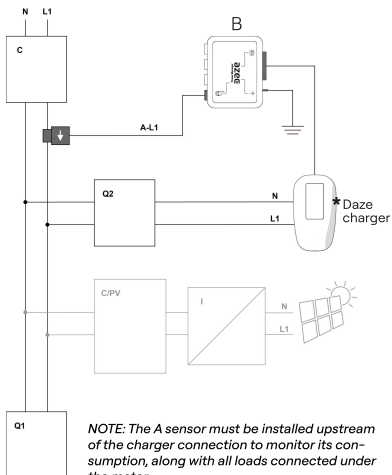
C: meter

Q1, Q2, ...: electrical cabinets

B: CT box board

A-L1 / L2 / L3: current sensor

C-PV: photovoltaic meter / I: photovoltaic inverter  
(if photovoltaic system is present)



### 4. Wiring diagram of PM03T30/PM03T100 in a three-phase system

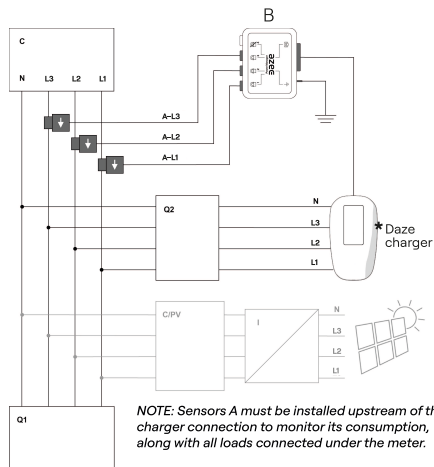
C: meter

Q1, Q2, ...: electrical cabinets

B: CT box board

A-L1: current sensor

C-PV: photovoltaic meter / I: photovoltaic inverter  
(if photovoltaic system is present)



4. The CT box (codes: PM02M, PM02T, PM02T100) can be mounted on a DIN rail by pulling and releasing the designated clip (Fig. 5). The compact CT box (codes: PM03M, PM03T30, PM03T100) can simply be placed freely inside the electrical panel.

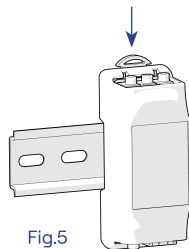


Fig.5

For the connection, the following is required:

- For **Dazebox C**, shown in Figures 3a and 4a, the shielded network cable must pass through a hole in the cable gland (PG) by breaking the blind bottom using a screwdriver. This cable gland has two Ø5 mm blind holes, one designated for the Power Manager and the other for the bipolar cable of the release coil (refer to the Dazebox C Installation Manual).
- For **Dazebox Home and Share T / S / TK / SK**, shown in Figures 3b, 3c, 3d, 3e, 3f, 3g, 3h, 3i, 4b, 4c, 4d, 4e, 4f, 4g, 4h, 4i, the shielded network cable passes through a hole in the cable entry membrane (M).
- For **Duo T / S**; shown in Figures 3l and 4l, the shielded network cable passes through a hole in the cable entry membrane (M).
- For **Urban T / S**, shown in Figures 3m and 4m, the shielded network cable passes through a hole in the cable entry membrane (M).

**NOTE:** To ensure proper operation of the Power Manager, sensor cable extensions cannot be used.

## Dazebox C

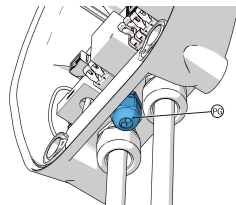


Fig. 3a

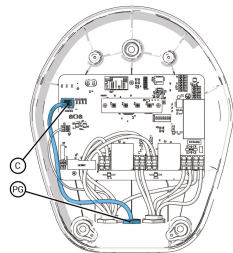


Fig. 4a

## Home T

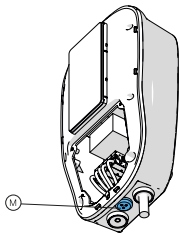


Fig. 3b

## Home S

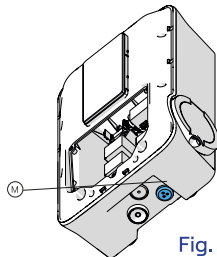


Fig. 3c

## Share T

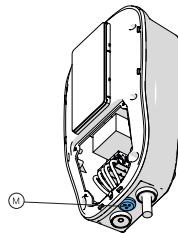


Fig. 3d

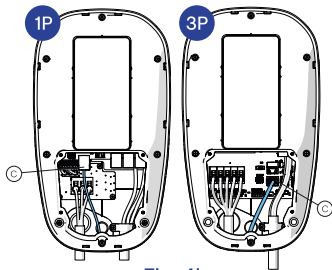


Fig. 4b

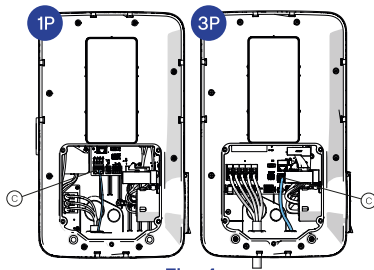


Fig. 4c

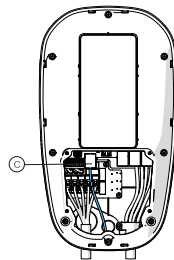


Fig. 4d

Share S

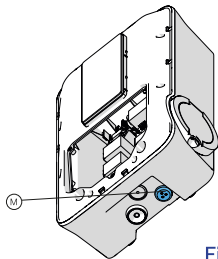


Fig. 3e

Home TK

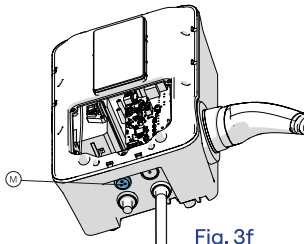


Fig. 3f

Home SK

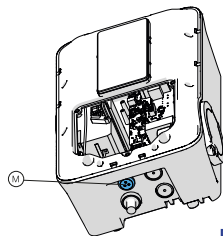


Fig. 3g

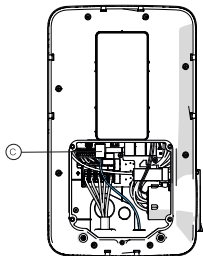


Fig. 4e

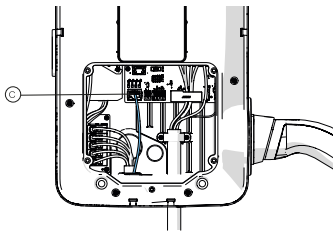


Fig. 4f

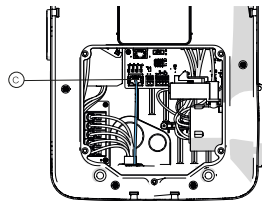


Fig. 4g

## Share TK

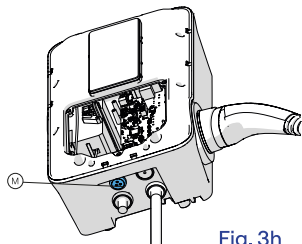


Fig. 3h

## Share SK

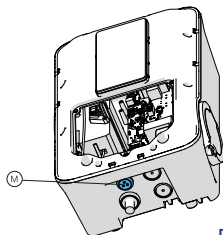


Fig. 3i

## Duo T/S

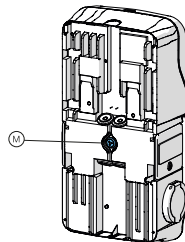


Fig. 3l

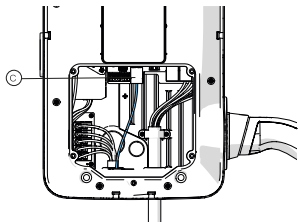


Fig. 4h

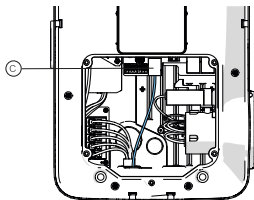


Fig. 4i

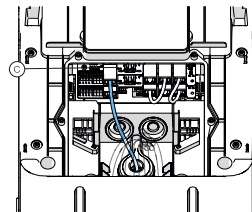


Fig. 4l

## Urban T/S

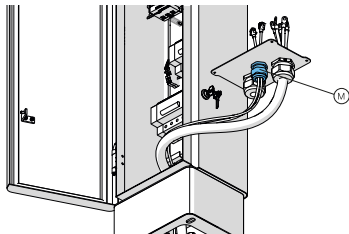


Fig. 3m

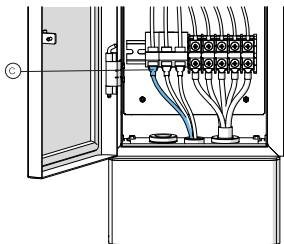
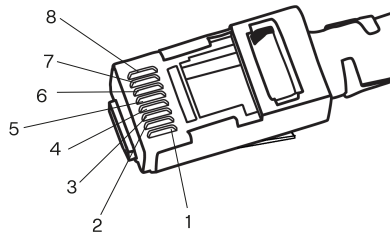


Fig. 4m

\* T-568B configuration table

Pin	T-568B
1	White/Orange
2	Orange
3	White/Green
4	Blue
5	White / Blue
6	Green
7	White / Brown
8	Brown



5. The second RJ45 connector provided in the package must be installed at the end of the network cable.
6. Strip 4 cm of the network cable, being careful not to remove the double shielding. Untwist and straighten the 8 wires and organize them according to the color scheme in the table (T-568B configuration)\*.
7. Insert the bend protection onto the cable. Arrange the wires in order within the designated channels of the connector and slide them in fully, close to the insulation.
8. Trim the wires flush with the end of the connector.
9. Crimp the prepared RJ45 connector using the appropriate crimping tool.
10. Ensure that the cable shielding is in contact with the metallic part of the RJ45 connector.
11. Check the correct wiring with a network cable tester before powering on.
12. Connect the newly assembled RJ45 terminal to the RJ45 port on the left side of the charger's board (C) (Figures 4a, 4b, 4c, 4d, 4e, 4f, 4g, 4h, 4i, 4l, and 4m).
13. Tighten the cable gland (PG) in the case of **Dazebox C** (Figure 3a).



The shielding of the network cable must be in contact with the metallic part of the RJ45 connector to ensure continuity with the female RJ45 connector on the board.

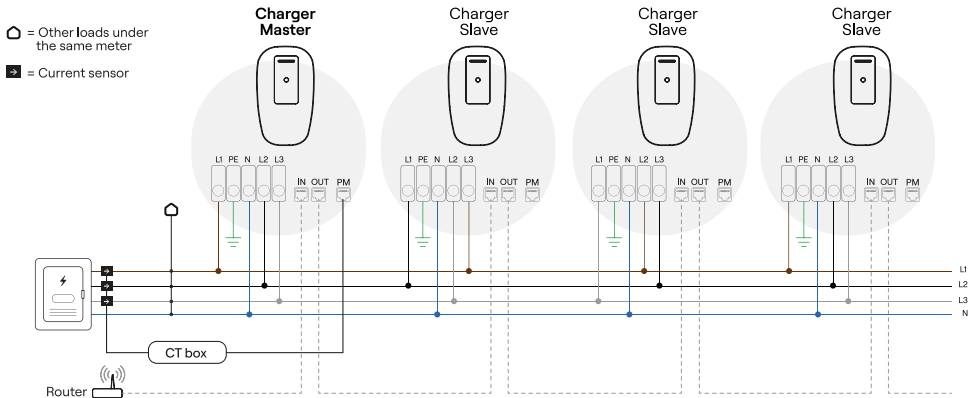
## 02.4 - Load Balancing between multiple chargers

For installations with multiple chargers under a single meter that is not exclusively dedicated to the charger network, the installation of the Power Manager also enables the Load Balancing function among multiple chargers with dynamic load management. Using a Master/Slave system, the chargers will dynamically distribute the available power among the charging vehicles, ensuring that the total consumption (chargers + other loads under the same meter) does not exceed the maximum limit set during network configuration.

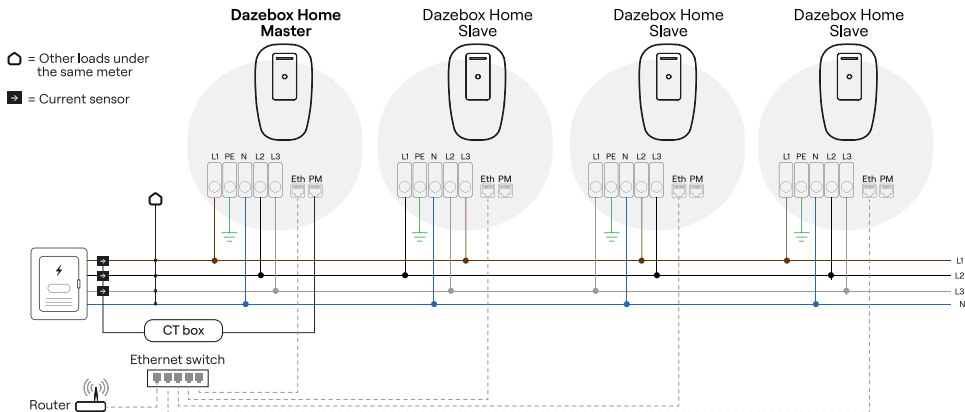
The CT box must be connected only to the Master charger, which is the first charger added to the network.

*Note: The Load Balancing function is also compatible with a WiFi connection; however, for more stable performance, an Ethernet cable connection is highly recommended.*

- For **Dazebox Share, Duo, and Urban**: Connect the CT box to the Ethernet port (PM) and the router to the Ethernet port (IN) of the Master (see figure below). For Slaves, connect the Ethernet OUT port of the Master to the IN port of the first Slave. Repeat the OUT/IN connection between the Slaves. Refer to the "Connections" chapter in the charger installation manual for port identification.



- **For Dazebox Home:** Connect the CT box to the designated Ethernet port (PM) of the Master charger. Both Master and Slave must be directly connected to the same router/switch through their respective Ethernet ports (Eth). Refer to the "Connections" chapter in the charger manual for port identification.



**IMPORTANT NOTE:** The Load Balancing function is compatible with both single-phase and three-phase systems. In the case of a three-phase system (where only three-phase chargers must be installed), it is important to evenly distribute the phases in the wiring of the different chargers to avoid overloading a single phase (see diagrams). During the Load Balancing configuration via the App, it is required to specify the phase order for each individual charger.

# 01 - Descrizione

Il Power Manager è un dispositivo che permette di modulare dinamicamente la potenza dedicata alla ricarica del veicolo in modo da non superare la potenza contrattuale del contatore, evitando blackout dovuti alla ricarica. Esistono due versioni differenti, il Power Manager per montaggio su barra DIN (codici: PM02M, PM02T, PM02T100 - Fig. 1A) e la versione compatta (codici: PM03M, PM03T30, PM03T100) per installazioni in spazi ridotti - Fig. 1B.

Dazebox C, Dazebox Home, Dazebox Share, Duo e Urban possono funzionare anche senza il Power Manager, la cui installazione non è obbligatoria. Tuttavia, in assenza di Power Manager, non è garantito che si eviti un blackout nel caso in cui venga superata la potenza del contatore impostata via app durante la fase di configurazione della rete.

Il Power Manager è costituito da 2 elementi:

- Scheda di controllo CT box plastico
- Sensore di corrente in versione monofase (PM02M PM03M) e trifase 30kW (PM02T PM03T30) in Fig. 1C e sensore per versione trifase 100kW (PM02T100 PM03T100) in Fig. 1D. Per le versioni Power Manager trifase verranno forniti 3 sensori di corrente.

Fig. 1A

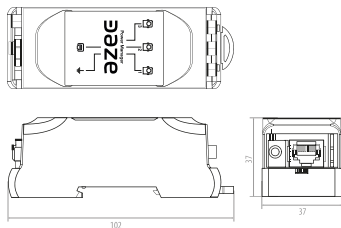


Fig. 1B

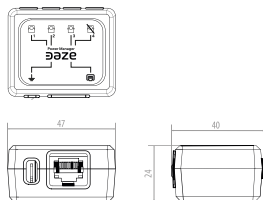


Fig. 1C

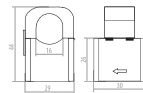
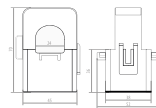


Fig. 1D



**Monofase**

PM02M / PM03M

**Trifase**PM02T / PM02T100  
PM03T30 / PM03T100

## Specifiche generali

### 1 Prodotti compatibili

Dazebox C: DB07\*\*M\* / DB07\*\*T\* / DB07\*\*M\*\*\* / DB07\*\*T\*\*\*  
 Dazebox Home: DT01\*\*32\*\* / DS01\*\*32\*\* / DK01\*\*32\*\*P / DS01\*\*32\*P  
 Dazebox Share: DT02\*\*32\*\* / DS02\*\*32\*\* / DK01\*\*32\*\*P / DS01\*\*32\*P  
 Duo: OT01\*\*64\*\*\*\* / OS01\*\*64\*\*\*  
 Urban: UT01IT64T\*\*\*\* / US01IT64T\*\*\*\*

## Specifiche elettriche

2	Potenza massima contatore	12,5 kW	37,5 kW / 100 kW *
3	Corrente massima per fase	55 A	55 A / 145 A

\* il Modulo Power Manger da 100 kW è compatibile solamente con Dazebox Home, Dazebox Share, Duo e Urban

## Installazione

4	Numero sensori di corrente	1	3
5	Massima sezione del cavo di fase	Fino a 50 mm <sup>2</sup>	Fino a 50 mm <sup>2</sup> / Fino a 120 mm <sup>2</sup>
6	Cavo di collegamento al caricatore (*non si garantisce che cavi di categoria superiore al Cat5e siano adeguati ai connettori RJ45 schermati forniti)	Cavo di rete CAT5e* schermato	
7	Schermatura cavo di rete	F o S/FTP - SF/FTP - SF/UTP - F/UTP	
8	Lunghezza cavo di collegamento sensore di corrente - CT box	900 mm	
9	Connessione a CT box	Jack 3,5 mm	
10	Lunghezza massima del cavo di rete da CT box al caricatore	170 m	
11	Montaggio	Guida DIN o con viti (PM) / Libero (PM compatto)	

## 02 – Installazione



L'allaccio del sensore per la funzione di Load Balancing richiede l'installazione da parte di un tecnico professionista.

**Nota Bene:** a valle di un contatore è possibile installare un solo Power Manager. In installazioni con più caricatori il Power Manager andrà collegato solamente al primo caricatore che sarà aggiunto alla rete, i rimanenti andranno aggiunti successivamente alla rete e cablati secondo lo schema del capitolo 2.4.

### 02.1 – Contenuto della confezione

Nella confezione viene fornito:

1. Sensore di corrente (1x versione monofase e 3x per versione trifase);
2. Scheda di controllo CT box;
3. Connettori RJ45 schermato con protezione antipiega (2x).

### 02.2 – Preparazione all'installazione

Necessario ma non incluso nella confezione:

- Cavo di rete per collegamento CT box al caricatore.
- Connettore Faston (femmina) e cavo per la messa a terra.

## 02.3 - Montaggio

**1.** Predisporre la posa di un cavo di rete di tipologia indicata nella sezione "Installazione" del capitolo "1" che colleghi la CT Box al luogo di installazione del caricatore.

**2.** Il sensore di corrente (A) va posizionato sul cavo di linea (L) in uscita dal contatore generale (C) prima di ogni ramificazione. Se in possesso di contatore trifase, posizionare i tre sensori rispettivamente su L1, L2, L3. Riferirsi agli schemi di collegamento a pagina 22-23 per posizionare il sensore nel verso corretto. Un errato posizionamento può causare malfunzionamenti.

**3.** Il sensore di corrente possiede un connettore jack (J) per la connessione con la scheda CT box (B). Sulla scheda è anche presente un ingresso RJ45 per il collegamento, tramite cavo di rete cat5e schermato, della CT box al sistema di ricarica.

I connettori RJ45 per cablare entrambe le estremità del cavo sono in dotazione. Le istruzioni di crimpaggio sono fornite dal punto 5 al punto 12, delle pagine successive. Effettuare la messa a terra tramite connettore Faston (come indicato in Fig. 2).

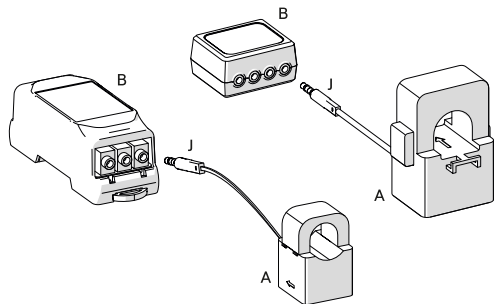
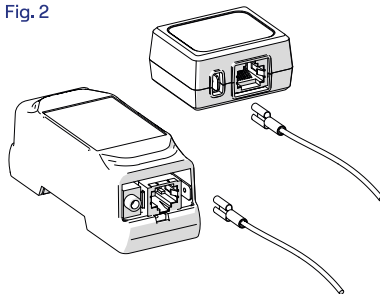


Fig. 2



## 1. Schema di collegamento di PM02M in impianto monofase

C: contatore

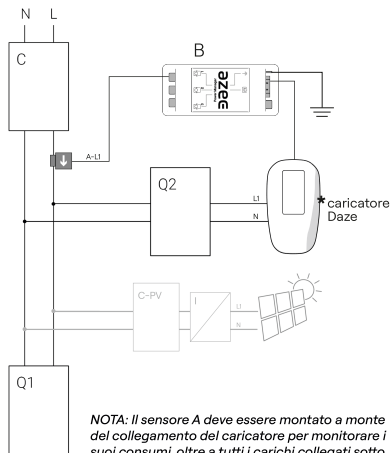
Q1, Q2, ...: armadi elettrici

B: scheda CT box

A-L1: sensore di corrente

C-PV: contatore fotovoltaico / I: inverter fotovoltaico

(se fotovoltaico presente)



## 2. Schema di collegamento di PM02T/PM02T100 in impianto trifase

C: contatore

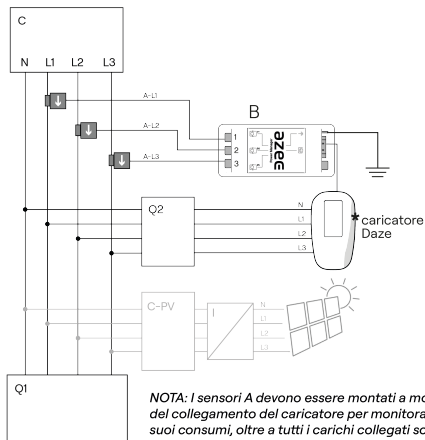
Q1, Q2, ...: armadi elettrici

B: scheda CT box

A-L1 / L2 / L3: sensore di corrente

C-PV: contatore fotovoltaico / I: inverter fotovoltaico

(se fotovoltaico presente)



### 3. Schema di collegamento di PM03M in impianto monofase

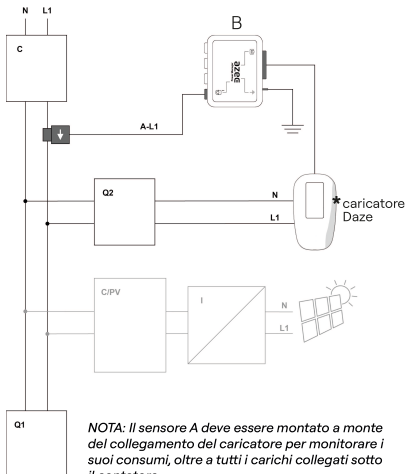
C: contatore

Q1, Q2, ...: armadi elettrici

B: scheda CT box

A-L1 / L2 / L3: sensore di corrente

C-PV: contatore fotovoltaico / I: inverter fotovoltaico  
(se fotovoltaico presente)



### 4. Schema di collegamento di PM03T30/PM03T100 in impianto trifase

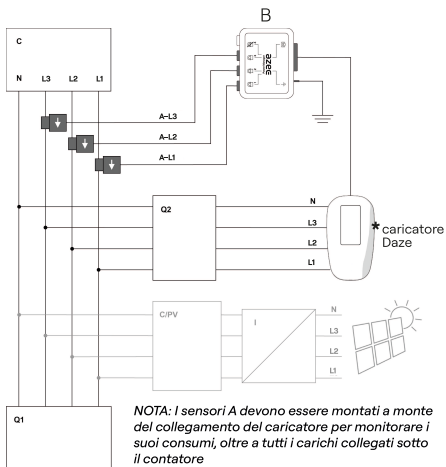
C: contatore

Q1, Q2, ...: armadi elettrici

B: scheda CT box

A-L1: sensore di corrente

C-PV: contatore fotovoltaico / I: inverter fotovoltaico  
(se fotovoltaico presente)



4. La CT box (codici: PM02M, PM02T, PM02T100) può essere fissata su guida DIN, bloccata tirando e rilasciando l'apposito gancetto (Fig 5). La CT box compatta (codici: PM03M, PM03T30, PM03T100) può essere semplicemente riposta liberamente all'interno del quadro elettrico.

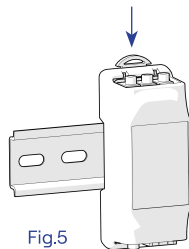


Fig.5

Per il collegamento è necessario:

- per **Dazebox C**, rappresentato in Figura 3a e 4a, il cavo di rete schermato deve passare attraverso un foro del pressacavo (PG), rompendo il fondo cieco tramite un cacciavite. Questo pressacavo ha due fori ciechi Ø5 mm, uno è adibito per il Power Manager, l'altro per il cavo bipolare della bobina di sgancio (consultare Manuale di installazione Dazebox C).
- per **Dazebox Home e Share T / S / TK / SK**, rappresentato in Figura 3b, 3c, 3d, 3e, 3f, 3g, 3h, 3i, 4b, 4c, 4d, 4e, 4f, 4g, 4h, 4i il cavo di rete schermato passa attraverso un foro della membrana passacavo (M).
- per **Duo T / S**, rappresentato in Figura 3i, 4i, il cavo di rete schermato passa attraverso un foro della membrana passacavo (M).
- per **Urban T / S**, rappresentato in Figura 3m, 4m, il cavo di rete schermato passa attraverso un foro della membrana passacavo (M).

**NOTA:** al fine del corretto funzionamento del Power Manager non è possibile utilizzare prolunghe per il cavo del sensore

## Dazebox C

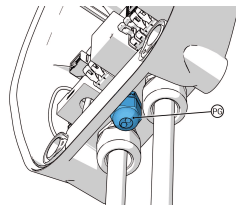


Fig. 3a

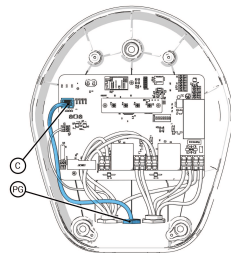


Fig. 4a

## Home T

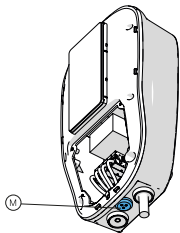


Fig. 3b

## Home S

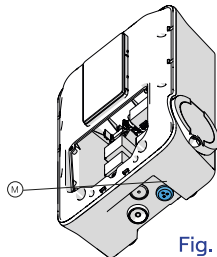


Fig. 3c

## Share T

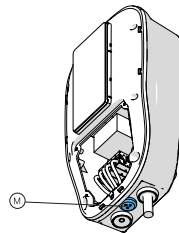


Fig. 3d

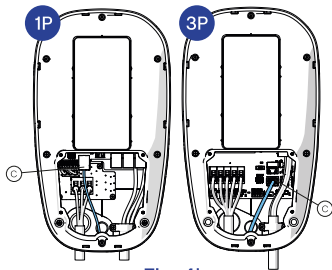


Fig. 4b

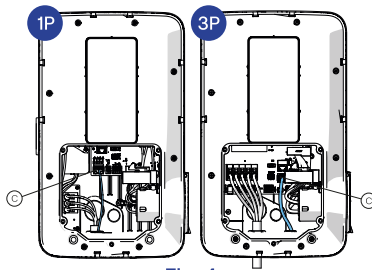


Fig. 4c

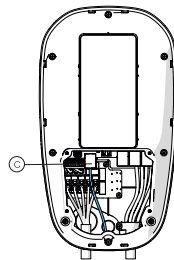


Fig. 4d

Share S

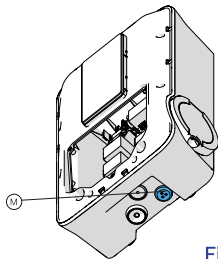
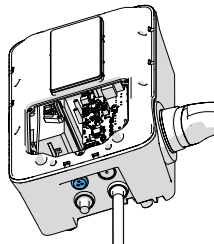


Fig. 3e

Home TK



Home SK

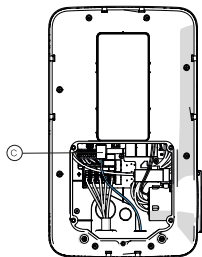
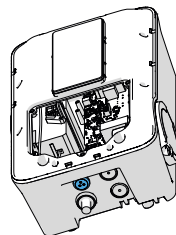


Fig. 4e

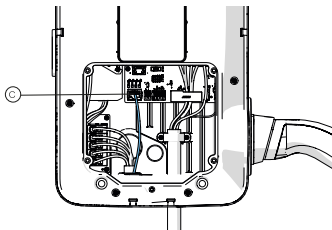


Fig. 4f

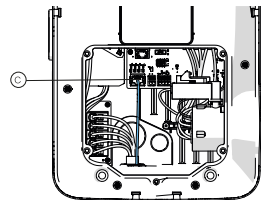
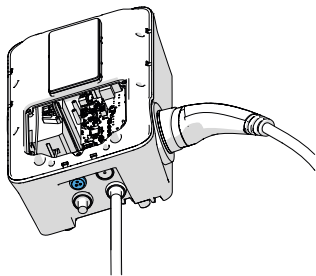


Fig. 4g

## Share TK



## Share SK

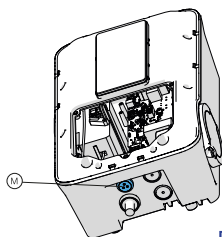


Fig. 3i

## Duo T/S

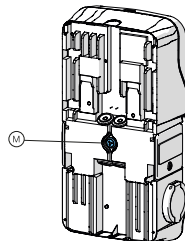


Fig. 3j

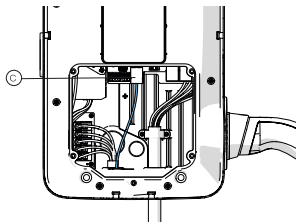


Fig. 4h

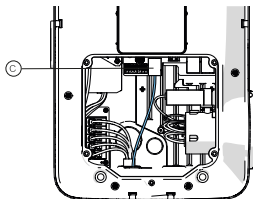


Fig. 4i

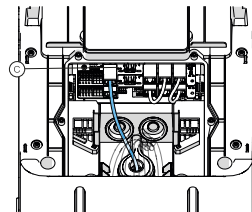


Fig. 4j

## Urban T/S

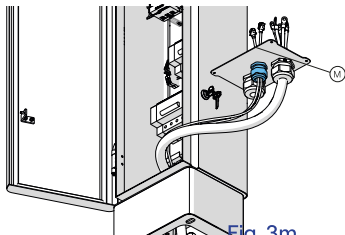


Fig. 3m

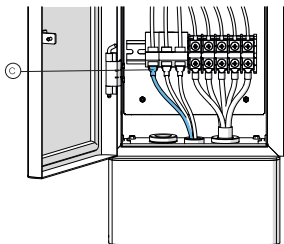
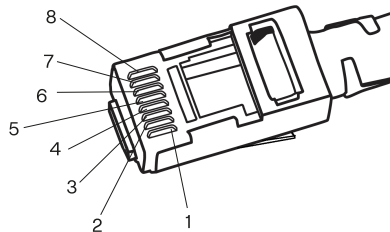


Fig. 4m

\* Tabella di configurazione T-568B

## Pin T-568B

Pin	T-568B
1	Bianco / Arancione
2	Arancione
3	Bianco / Verde
4	Blu
5	Bianco / Blu
6	Verde
7	Bianco / Marrone
8	Marrone



5. Il secondo RJ45 fornito in confezione deve essere installato all'estremità del cavo di rete.
6. Spelare 4 cm di cavo di rete, facendo attenzione a non rimuovere la doppia schermatura. Disintrecciare e raddrizzare gli 8 fili e organizzarli secondo lo schema di colori riportato in tabella (configurazione T-568B) \*
7. Inserire nel cavo la protezione anti piega. Inserire i cavi in ordine negli appositi canali del connettore e farli scorrere fino in fondo, in prossimità dell'isolante.
8. Tagliare i cavi a filo dell'estremità del connettore.
9. Crimpare il connettore RJ45 così preparato con l'apposita pinza.
10. È importante che la schermatura del cavo sia in contatto con la parte metallica del connettore RJ45.
11. Verificare il corretto cablaggio con un tester per cavo di rete prima della messa in funzione.
12. Connettere il terminale RJ45 appena montato alla porta RJ45 a sinistra della scheda (C) del caricatore (Figura 4a, 4b, 4c, 4d, 4e, 4f, 4g, 4h, 4i, 4l e 4m).
13. Stringere il pressacavo (PG), nel caso di Dazebox C (Figura 3a).



La schermatura del cavo di rete deve essere in contatto con la parte metallica del connettore RJ45 affinché abbia continuità con il connettore RJ45 femmina posto sulla scheda.

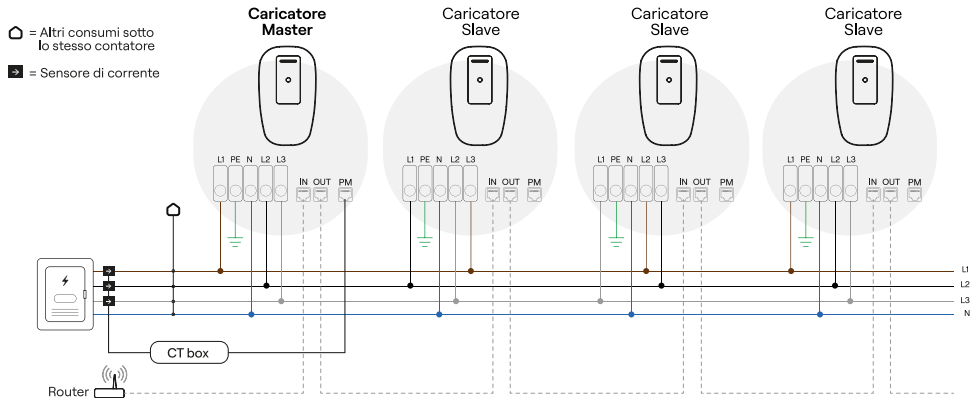
## 02.4 - Load Balancing tra più caricatori

Per casi di installazioni di più di un caricatore sotto un unico contatore non unicamente dedicato alla rete di caricatori, l'installazione del Power Manager abilita anche la funzionalità di Load Balancing tra più caricatori con gestione dinamica del carico: attraverso un sistema Master/Slave, i caricatori saranno abilitati a distribuire dinamicamente la potenza disponibile tra i veicoli in carica, assicurandosi che il consumo complessivo (caricatori + altri carichi sotto lo stesso contatore) non superi il limite massimo impostato durante la configurazione della rete.

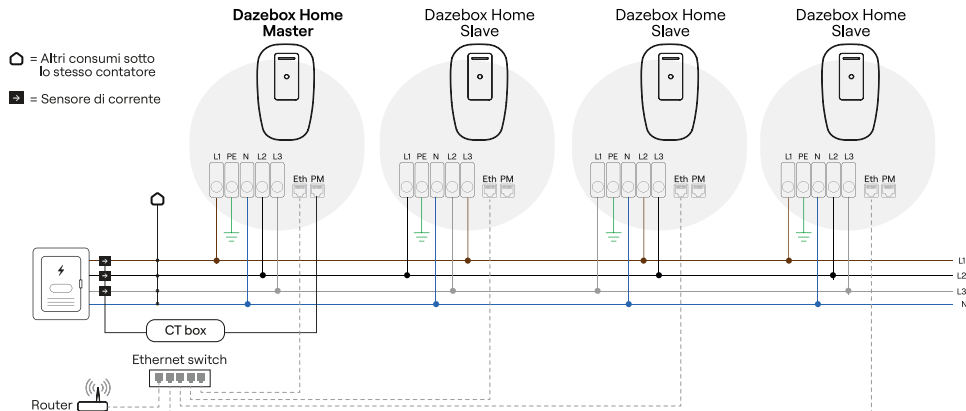
La CT box dovrà essere collegata solamente al caricatore Master, ovvero il primo caricatore aggiunto alla rete.

*Nota: la funzionalità Load Balancing è compatibile anche con una connessione WiFi, tuttavia per prestazioni più stabili è altamente consigliata la connessione tramite cavo Ethernet.*

- Per **Dazebox Share, Duo e Urban**: collegare la CT box alla porta ethernet (PM) e il router alla porta ethernet (IN) del Master (vedi figura sotto). Per gli Slaves, collegare la porta Ethernet di uscita (OUT) del Master alla porta di ingresso (IN) del primo Slave. Ripetere il collegamento OUT/IN tra gli Slave. Consultare il capitolo "Collegamenti" del manuale di installazione del caricatore per l'identificazione delle porte.



- Per **Dazebox Home**: collegare la CT box all'apposita porta ethernet (PM) del caricatore master. Sia Master che Slave devono essere collegati direttamente allo stesso router/switch attraverso la propria porta ethernet (Eth). Consultare il capitolo "Collegamenti" del manuale del caricatore per l'identificazione delle porte.



**NOTA BENE:** La funzionalità Load Balancing è compatibile sia con impianti monofase sia con impianti trifase. Nel caso di impianto trifase (in cui devono essere installati solo caricatori trifase) è importante distribuire equamente le fasi nel cablaggio dei diversi caricatori al fine di evitare un sovraccarico su una singola fase (vedi schemi). Durante la configurazione via App della funzionalità Load Balancing è richiesto di riportare l'ordine delle fasi su ogni singolo caricatore.

# 01 - Description

Le Power Manager est un dispositif qui permet de moduler dynamiquement la puissance dédiée à la recharge du véhicule afin de ne pas dépasser la puissance contractuelle du compteur, évitant ainsi les coupures de courant dues à la recharge.

Il existe deux versions différentes, le Power Manager pour montage sur rail DIN (codes : PM02M, PM02T, PM02T100 - Fig. 1A) et la version compacte (codes : PM03M, PM03T30, PM03T100) pour des installations dans des espaces réduits - Fig. 1B.

Dazebox C, Dazebox Home, Dazebox Share, Duo et Urban peuvent également fonctionner sans le Power Manager, dont l'installation n'est pas obligatoire. Toutefois, en l'absence de Power Manager, il n'est pas garanti qu'une coupure de courant soit évitée si la puissance du compteur définie via l'application lors de la configuration du réseau est dépassée.

Le Power Manager est constitué de 2 éléments :

- Carte de contrôle CT box en plastique
- Capteur de courant en version monophasée (PM02M PM03M) et triphasée 30 kW (PM02T PM03T30) en Fig. 1C, ainsi que capteur pour la version triphasée 100 kW (PM02T100 PM03T100) en Fig. 1D. Pour les versions Power Manager triphasées, 3 capteurs de courant sont fournis.

Fig. 1A

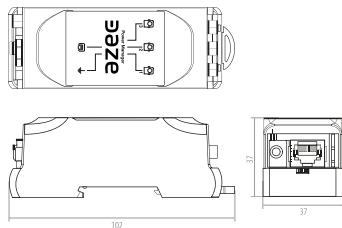


Fig. 1B

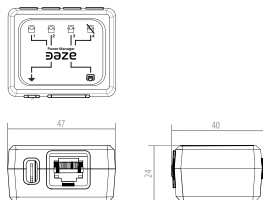


Fig. 1C

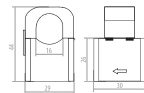
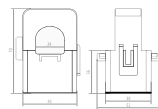


Fig. 1D



**Monophasé**

PM02M / PM03M

**Triphasé**PM02T / PM02T100  
PM03T30 / PM03T100

## Spécifications générales

### 1 Produits compatibles

Dazebox C: DB07\*\*M\* / DB07\*\*T\* / DB07\*\*M\*\*\* / DB07\*\*T\*\*\*  
 Dazebox Home: DT01\*\*32\*\* / DS01\*\*32\*\* / DK01\*\*32\*\*P / DS01\*\*32\*P  
 Dazebox Share: DT02\*\*32\*\* / DS02\*\*32\*\* / DK01\*\*32\*\*P / DS01\*\*32\*P  
 Duo: OT01\*\*64\*\*\*\* / OS01\*\*64\*\*\*  
 Urban: UT01IT64T\*\*\*\*\* / US01IT64T\*\*\*\*\*

## Spécifications électriques

2 Puissance maximale du compteur	12,5 kW	37,5 kW / 100 kW *
3 Courant maximal par phase	55 A	55 A / 145 A

\* Le module Power Manager de 100 kW est uniquement compatible avec Dazebox Home, Dazebox Share, Duo et Urban

## Installation

4 Nombre de capteurs de courant	1	3
5 Section maximale du câble de phase	Jusqu'à 50 mm <sup>2</sup>	Jusqu'à 50 mm <sup>2</sup> / Jusqu'à 120 mm <sup>2</sup>
6 Câble de connexion à la borne de recharge (*il n'est pas garanti que des câbles de catégorie supérieure à Cat5e soient adaptés aux connecteurs RJ45 blindés fournis)	Câble réseau CAT5e* blindé	
7 Blindage du câble réseau	F o S/FTP - SF/FTP - SF/UTP - F/UTP	
8 Longueur du câble de connexion du capteur de courant - CT box	900 mm	
9 Connexion à la CT box	Jack 3,5 mm	
10 Longueur maximale du câble réseau de la CT box à la borne de recharge	170 m	
11 Montage	Rail DIN ou avec vis (PM) / Libre (PM compact)	

## 02 – Installation



Le raccordement du capteur pour la fonction d'Équilibrage de Puissance nécessite l'installation par un technicien professionnel.

**Note :** En aval d'un compteur, un seul Power Manager peut être installé. Dans les installations avec plusieurs bornes de recharge, le Power Manager doit être connecté uniquement à la première borne ajoutée au réseau. Les bornes restantes devront être ajoutées ultérieurement au réseau et câblées selon le schéma du chapitre 2.4.

### 02.1 – Contenu de l'emballage

Le contenu de l'emballage comprend :

1. Capteur de courant (1x pour la version monophasée et 3x pour la version triphasée) ;
2. Carte de contrôle CT box ;
3. Connecteurs RJ45 blindés avec protection anti-pliure (2x).

### 02.2 – Préparation à l'installation

Nécessaire mais non inclus dans l'emballage :

- Câble réseau pour la connexion de la CT box à la borne de recharge.
- Connecteur Faston (femelle) et câble pour la mise à la terre.

## 02.3 - Montage

**1.** Préparer la pose d'un câble réseau du type indiqué dans la section « Installation » du chapitre « 1 » pour connecter la CT Box au lieu d'installation de la borne de recharge.

**2.** Le capteur de courant (A) doit être positionné sur le câble de ligne (L) en sortie du compteur général (C) avant toute ramification. En cas de compteur triphasé, placer les trois capteurs respectivement sur L1, L2 et L3. Se référer aux schémas de connexion aux pages 22-23 pour positionner correctement le capteur. Un mauvais positionnement peut entraîner des dysfonctionnements.

**3.** Le capteur de courant possède un connecteur jack (J) pour la connexion à la carte CT box (B). La carte dispose également d'une entrée RJ45 pour le raccordement de la CT box au système de recharge à l'aide d'un câble réseau Cat5e blindé. Les connecteurs RJ45 pour câbler les deux extrémités du câble sont fournis. Les instructions de sertissage sont détaillées du point 5 au point 12, dans les pages suivantes. Effectuer la mise à la terre à l'aide d'un connecteur Faston (comme indiqué en Fig. 2).

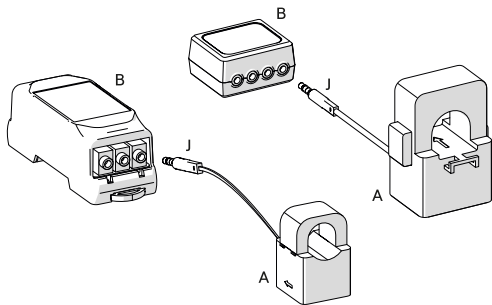
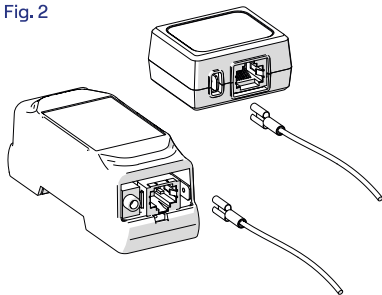


Fig. 2



## 1. Schéma de connexion du PM02M dans une installation monophasée

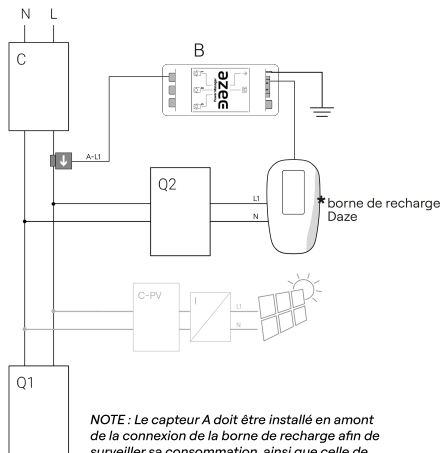
C : compteur

Q1, Q2, ... : armoires électriques

B : carte CT box

A-L1 : capteur de courant

C-PV : compteur photovoltaïque / I : onduleur photovoltaïque  
(si système photovoltaïque est présent)



## 2. Schéma de connexion du PM02T/PM02T100 dans une installation triphasée

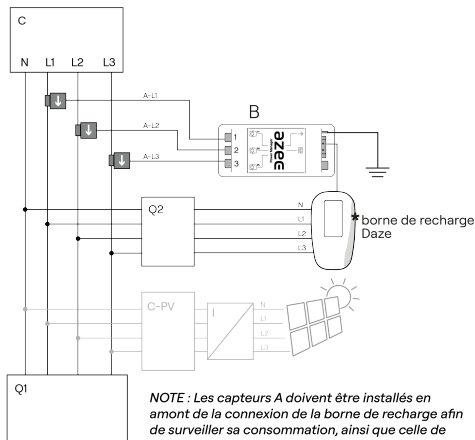
C : compteur

Q1, Q2, ... : armoires électriques

B : carte CT box

A-L1 / L2 / L3 : capteur de courant

C-PV : compteur photovoltaïque / I : onduleur photovoltaïque  
(si un système photovoltaïque est présent)



### 3. Schéma de connexion du PM03M dans une installation monophasée

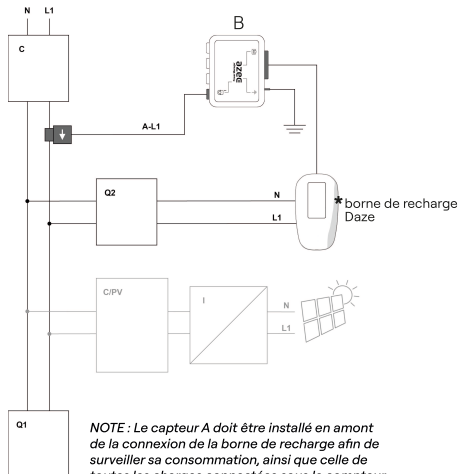
C : compteur

Q1, Q2, ... : armoires électriques

B : carte CT box

A-L1 / L2 / L3 : capteur de courant

C-PV : compteur photovoltaïque / I : onduleur photovoltaïque  
(si photovoltaïque est présent)



### 4. Schéma de connexion du PM03T30/PM03T100 dans une installation triphasée

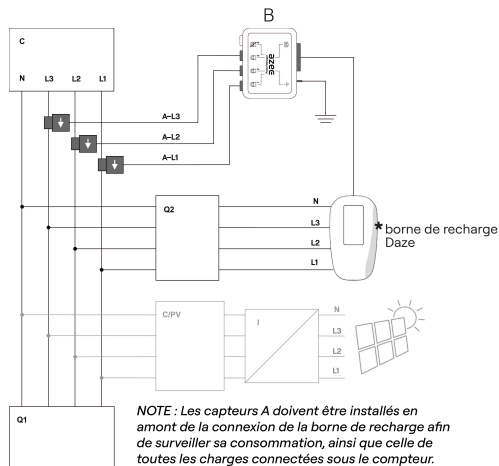
C : compteur

Q1, Q2, ... : armoires électriques

B : carte CT box

A-L1 : capteur de courant

C-PV : compteur photovoltaïque / I : onduleur photovoltaïque  
(si un système photovoltaïque est présent)



4. La CT box (codes : PM02M, PM02T, PM02T100) peut être fixée sur un rail DIN, en la verrouillant en tirant et relâchant le crochet prévu à cet effet (Fig. 5). La CT box compacte (codes : PM03M, PM03T30, PM03T100) peut être simplement placée librement à l'intérieur du tableau électrique.

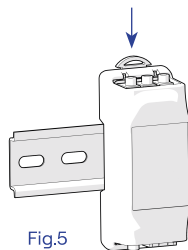


Fig.5

Pour la connexion, il est nécessaire :

- Pour **Dazebox C**, représenté en Figures 3a et 4a, le câble réseau blindé doit passer par un trou du presse-câble (PG), en brisant le fond aveugle à l'aide d'un tournevis. Ce presse-câble possède deux trous aveugles Ø5 mm, l'un destiné au Power Manager, l'autre pour le câble bipolaire de la bobine de déconnexion (consulter le manuel d'installation de Dazebox C).

- Pour **Dazebox Home et Share T / S / TK / SK**, représenté en Figures 3b, 3c, 3d, 3e, 3f, 3g, 3h, 3i, 4b, 4c, 4d, 4e, 4f, 4g, 4h, 4i, le câble réseau blindé passe par un trou de la membrane passe-câble (M).

- Pour **Duo T / S**, représenté en Figures 3l et 4l, le câble réseau blindé passe par un trou de la membrane passe-câble (M).

- Pour **Urban T / S**, représenté en Figures 3m et 4m, le câble réseau blindé passe par un trou de la membrane passe-câble (M).

**NOTE :** Pour le bon fonctionnement du Power Manager, il n'est pas possible d'utiliser des rallonges pour le câble du capteur.

## Dazebox C

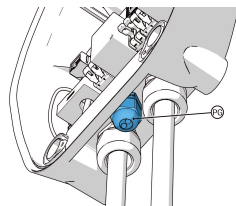


Fig. 3a

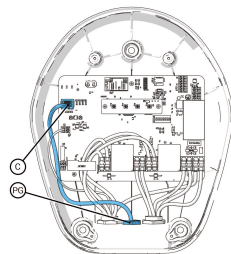


Fig. 4a

## Home T

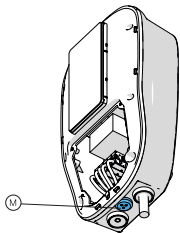


Fig. 3b

## Home S

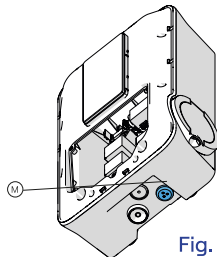


Fig. 3c

## Share T

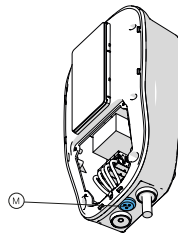


Fig. 3d

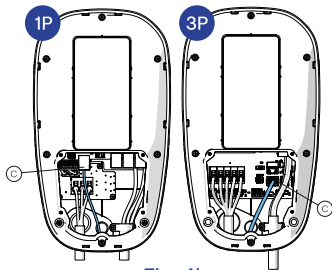


Fig. 4b

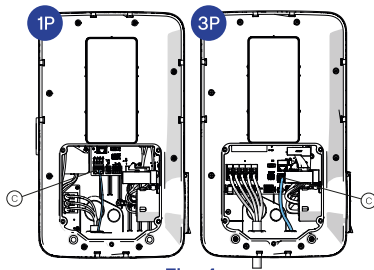


Fig. 4c

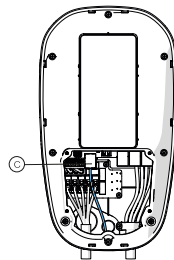


Fig. 4d

Share S

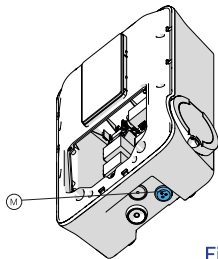


Fig. 3e

Home TK

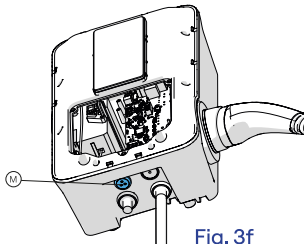


Fig. 3f

Home SK

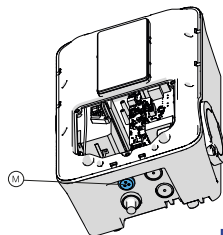


Fig. 3g

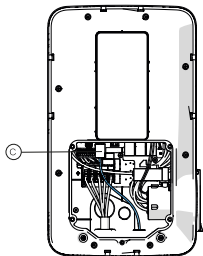


Fig. 4e

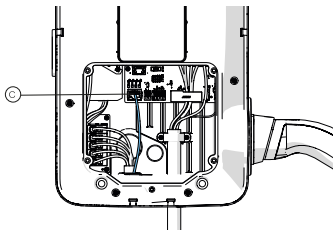


Fig. 4f

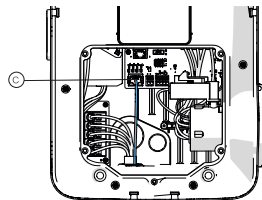


Fig. 4g

## Share TK

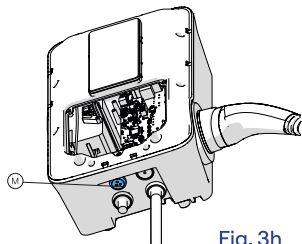


Fig. 3h

## Share SK

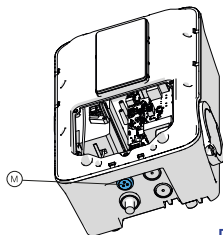


Fig. 3i

## Duo T/S

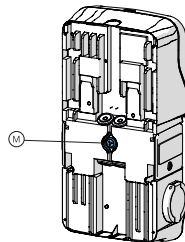


Fig. 3l

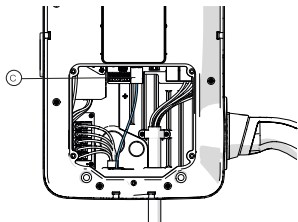


Fig. 4h

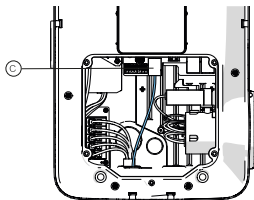


Fig. 4i

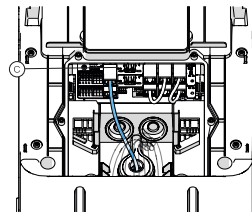


Fig. 4l

## Urban T/S

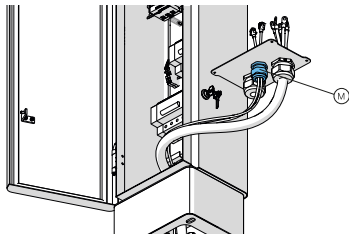


Fig. 3m

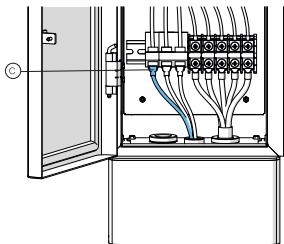
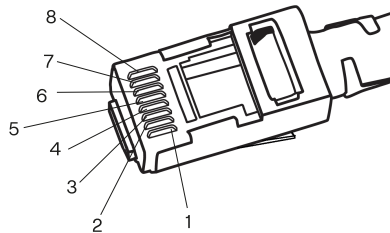


Fig. 4m

\* Tableau de configuration T-568B

Pin	T-568B
1	Blanc / Orange
2	Orange
3	Blanc / Vert
4	Blue
5	Blanc / Blue
6	Vert
7	Blanc / Marron
8	Marron



5. Le deuxième RJ45 fournie dans l'emballage doit être installée à l'extrémité du câble réseau.
6. Dénuder 4 cm du câble réseau, en veillant à ne pas retirer le double blindage. Démêler et redresser les 8 fils et les organiser selon le schéma de couleurs indiqué dans le tableau (configuration T-568B)\*.
7. Insérer la protection anti-pliure dans le câble. Insérer les fils dans l'ordre dans les canaux du connecteur et les faire glisser jusqu'au fond, près de l'isolant.
8. Couper les fils au ras de l'extrémité du connecteur.
9. Crimper le connecteur RJ45 ainsi préparé avec la pince appropriée.
10. Il est important que le blindage du câble soit en contact avec la partie métallique du connecteur RJ45.
11. Vérifier le câblage correct avec un testeur de câble réseau avant la mise en service.
12. Connecter le terminal RJ45 nouvellement monté à la prise RJ45 à gauche de la carte (C) de la borne (Figures 4a, 4b, 4c, 4d, 4e, 4f, 4g, 4h, 4i, 4l et 4m).
13. Serrer le presse-câble (PG), dans le cas de Dazebox C (Figure 3a).



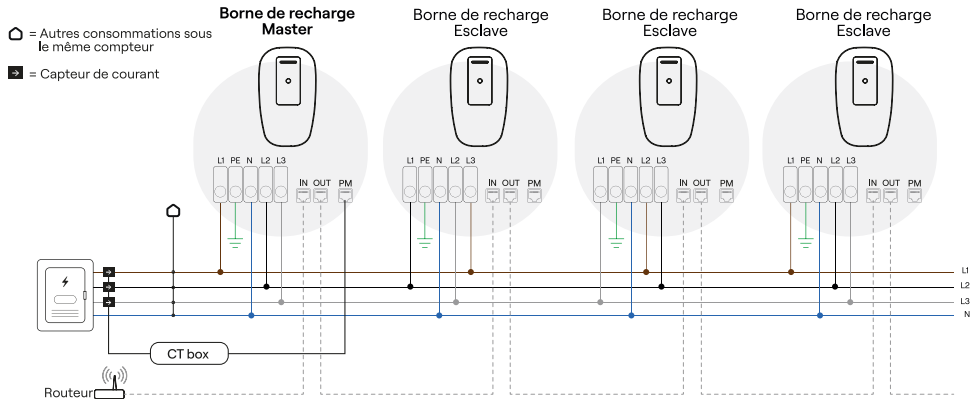
Le blindage du câble réseau doit être en contact avec la partie métallique du connecteur RJ45 afin d'assurer la continuité avec le connecteur RJ45 femelle situé sur la carte.

## 02.4 - Équilibrage de Puissance entre plusieurs bornes de recharge

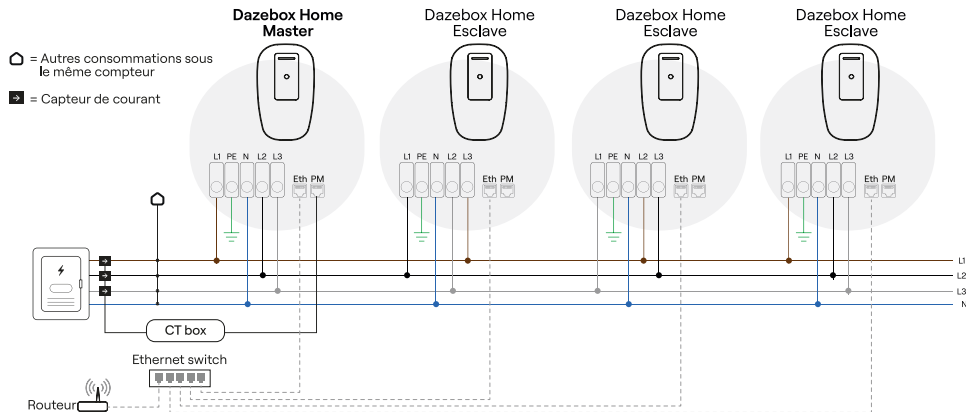
Pour les cas d'installations de plusieurs bornes de recharge sous un unique compteur qui n'est pas uniquement dédié au réseau de bornes, l'installation du Power Manager active également la fonctionnalité d'Équilibrage de Puissance entre plusieurs bornes avec gestion dynamique de la charge : grâce à un système Master/Esclave, les bornes de recharge seront capables de distribuer dynamiquement la puissance disponible entre les véhicules en charge, en s'assurant que la consommation totale (bornes de recharge + autres charges sous le même compteur) ne dépasse pas la limite maximale définie lors de la configuration du réseau. La CT box doit être connectée uniquement à la borne de recharge Master, c'est-à-dire la première borne ajoutée au réseau.

*Note : La fonctionnalité Équilibrage de Puissance est également compatible avec une connexion WiFi, cependant, pour des performances plus stables, la connexion via câble Ethernet est fortement recommandée.*

- Pour Dazebox Share, Duo et Urban : connecter la CT box à la prise Ethernet (PM) et le routeur à la prise Ethernet (IN) de la Master (voir figure ci-dessous). Pour les Esclaves, connecter la prise Ethernet de sortie (OUT) de la Master à la prise d'entrée (IN) de la première Esclave. Répéter la connexion OUT/IN entre les Esclaves. Veuillez faire référence au chapitre "Connexions" du manuel d'installation de la borne de recharge pour l'identification des prises.



- Pour **Dazebox Home** : connecter la CT box à la prise Ethernet (PM) de la borne de recharge Master. La Master et l'Esclave doivent être directement connectées au même routeur/switch via leur propre prise Ethernet (Eth). Veuillez faire référence au chapitre "Connexions" du manuel de la borne de recharge pour l'identification des prises.



**NOTE** : La fonctionnalité Équilibrage de Puissance est compatible avec les installations monophasées et triphasées. Dans le cas d'une installation triphasée (où seules des bornes de recharge triphasées doivent être installées), il est important de répartir équitablement les phases dans le câblage des différentes bornes de recharge afin d'éviter une surcharge sur une seule phase (voir les schémas). Lors de la configuration de la fonctionnalité Équilibrage de Puissance via l'application, il est nécessaire d'indiquer l'ordre des phases pour chaque borne de recharge.

# 01 – Beschreibung

Der Power Manager ist ein Gerät, das es ermöglicht, die für das Laden des Fahrzeugs zugewiesene Leistung dynamisch zu steuern, um die vertragliche Leistung des Zählers nicht zu überschreiten und so Stromausfälle aufgrund des Ladevorgangs zu vermeiden. Es gibt zwei verschiedene Versionen: den Power Manager zur Montage auf einer DIN-Schiene (Codes: PM02M, PM02T, PM02T100 - Abb. 1A) und die kompakte Version (Codes: PM03M, PM03T30, PM03T100) für Installationen in engen Räumen - Abb. 1B.

Dazebox C, Dazebox Home, Dazebox Share, Duo und Urban können auch ohne den Power Manager betrieben werden. Die Installation des Power Managers ist nicht zwingend erforderlich. Allerdings kann in Abwesenheit des Power Managers nicht garantiert werden, dass ein Stromausfall vermieden wird, wenn die über die App während der Netzwerkkonfiguration eingestellte Zählerleistung überschritten wird.

Der Power Manager besteht aus 2 Komponenten:

- Steuerplatine CT-Box aus Kunststoff
- Stromsensor in der einphasigen Version (PM02M PM03M) und der dreiphasigen 30kW Version (PM02T PM03T30) in Abb. 1C und Sensor für die dreiphasige 100kW Version (PM02T100 PM03T100) in Abb. 1D. Für die dreiphasigen Versionen des Power Managers werden 3 Stromsensoren geliefert.

Abb. 1A

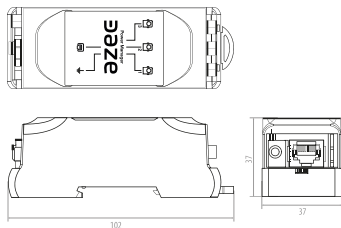


Abb. 1B

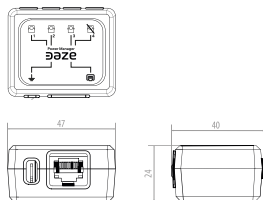


Abb. 1C

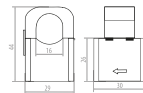
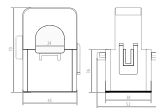


Abb. 1D



**Einphasig**

PM02M / PM03M

**Dreiphasig**PM02T / PM02T100  
PM03T30 / PM03T100

## Allgemeine Spezifikationen

- 1 Kompatible Produkte

Dazebox C: DB07\*\*M\* / DB07\*\*T\* / DB07\*\*M\*\*\* / DB07\*\*T\*\*\*  
 Dazebox Home: DT01\*\*32\*\* / DS01\*\*32\*\* / DK01\*\*32\*\*P / DS01\*\*32\*\*P  
 Dazebox Share: DT02\*\*32\*\* / DS02\*\*32\*\* / DK01\*\*32\*\*P / DS01\*\*32\*\*P  
 Duo: OT01\*\*64\*\*\*\* / OS01\*\*64\*\*\*\*  
 Urban: UT01IT64T\*\*\*\* / US01IT64T\*\*\*\*

## Elektrische Spezifikationen

2 Maximale Zählerleistung	12,5 kW	37,5 kW / 100 kW *
3 Maximaler Strom pro Phase	55 A	55 A / 145 A

\* Das Power Manager Modul mit 100 kW ist nur mit Dazebox Home, Dazebox Share, Duo und Urban kompatibel

## Installation

4 Anzahl der Stromsensoren	1	3
5 Maximale Kabeldurchführung des Stromsensoren	Bis zu 50 mm <sup>2</sup>	Bis zu 50 mm <sup>2</sup> / Bis zu 120 mm <sup>2</sup>
6 Verbindungskabel zum Ladegerät (*Es ist nicht garantiert, dass Kabel höherer Kategorie als Cat5e mit den mitgelieferten geschirmten RJ45-Steckverbindern kompatibel sind*)	Geschirmtes CAT5e-Netzwerkkabel*	
7 Abschirmung des Netzwerkkabels	F oder S/FTP - SF/FTP - SF/UTP - F/UTP	
8 Länge des Verbindungskabels zum - CT-Box	900 mm	
9 Verbindung zum CT-Box	Jack 3,5 mm	
10 Maximale Länge des Netzwerkkabels von der CT-Box zum Ladegerät	170 m	
11 Montage	DIN-Schiene oder mit Schrauben (PM) / Frei (kompaktes PM)	

## 02 – Installation



Der Anschluss des Sensors für das Lastmanagement erfordert die Installation durch einen professionellen Techniker. **Hinweis: Unter einem Zähler kann nur ein Power Manager installiert werden. Bei Installationen mit mehreren Ladestationen muss der Power Manager nur mit der erste Ladestation verbunden werden, das zum Netzwerk hinzugefügt wird. Die restliche Ladestationen müssen später zum Netzwerk hinzugefügt und gemäß dem Schema im Kapitel 2.4 verkabelt werden.**

### 02.1 – Inhalt der Verpackung

In der Verpackung ist folgendes enthalten:

1. Stromsensor (1x für einphasige Version und 3x für dreiphasige Version);
2. Steuerplatine CT-Box;
3. Geschirmte RJ45-Steckverbinder mit Knickschutz (2x).

### 02.2 – Vorbereitung der Installation

Erforderlich, aber nicht in der Verpackung enthalten:

- Netzkabel für die Verbindung der CT-Box mit dem Ladegerät.
- Faston-Steckverbinder (weiblich) und Kabel für die Erdung.

## 02.3 – Montage

**1.** Bereiten Sie das Verlegen eines Netzkabels , wie in der Paragraph „Installations“ von Kapitel „1“ angegeben, vor, das die CT-Box mit Ladestation verbindet.

**2.** Der Stromsensor (A) muss, vor jeder Abzweigung, am Leistungskabel (L), der aus dem Hauptzähler (C) kommt, installiert werden. Bei einem dreiphasigen Zähler müssen die drei Sensoren jeweils auf L1, L2 und L3 installiert werden. Weitere Details zur richtigen Positionierung des Sensors finden Sie in den Verkabelungsschemas auf den Seiten 22-23. Eine falsche Positionierung kann zu Fehlfunktionen führen.

**3.** Der Stromsensor verfügt über einen Jack-Anschluss (J) für die Verbindung mit der CT-Box-Platine (B). Auf der Platine befindet sich auch ein RJ45-Anschluss für die Verbindung der CT-Box mit dem Ladesystem über ein geschirmtes Cat5e-Netzwerkabel. Die RJ45-Steckverbinder zum Verkabelung beider Kabelenden sind in der Verpackung enthalten. Die Anweisungen zum Crimpen sind in den Punkten 5 bis 12 der folgenden Seiten angegeben. Die Erdung erfolgt über einen Faston-Steckverbinder (wie in Abb. 2 angegeben).

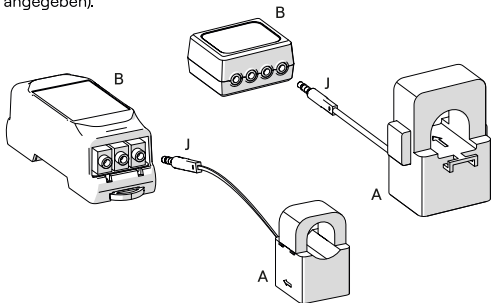
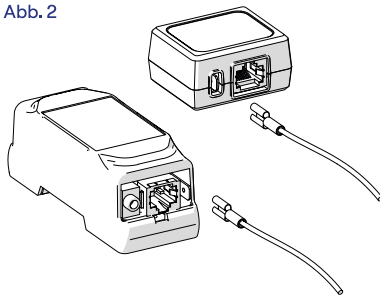


Abb. 2



## 1. Schaltplan der Verbindung von PM02M in einer einphasigen Installation

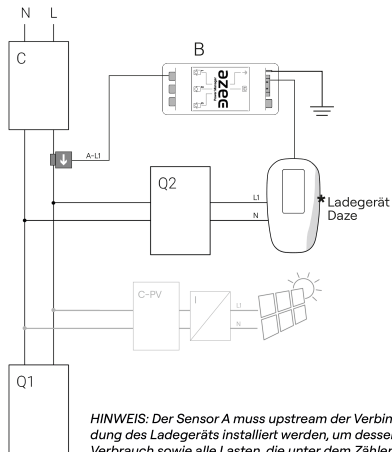
C: Zähler

Q1, Q2, ...: Schaltschranke

B: CT-Box-Steuerplatine

A-L1: Stromsensor

C-PV: Photovoltaikzähler / I: Photovoltaik-Wechselrichter (falls Photovoltaikanlage vorhanden ist)



## 2. Schaltplan der Verbindung von PM02T/PM02T100 in einer dreiphasigen Installation

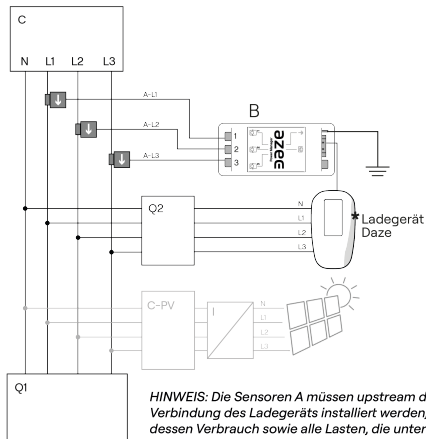
C: Zähler

Q1, Q2, ...: Schaltschranke

B: CT-Box-Steuerplatine

A-L1 / L2 / L3: Stromsensor

C-PV: Photovoltaikzähler / I: Photovoltaik-Wechselrichter (falls Photovoltaikanlage vorhanden ist)



### 3. Schaltplan der Verbindung von PM03M in einer einphasigen Installation

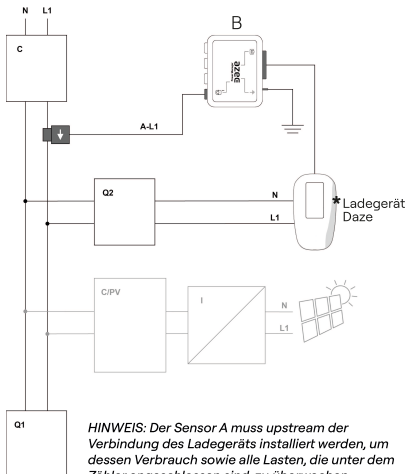
C: Zähler

Q1, Q2, ...: Schaltschranke

B: CT-Box-Steuerplatine

A-L1 / L2 / L3: Stromsensor

C-PV: Photovoltaikzähler / I: Photovoltaik-Wechselrichter  
(falls Photovoltaikanlage vorhanden ist)



### 4. Schaltplan der Verbindung von PM03T30/PM03T100 in einer dreiphasigen Installation

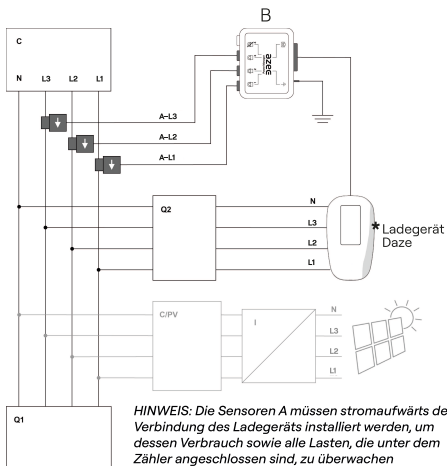
C: Zähler

Q1, Q2, ...: Schaltschranke

B: CT-Box-Steuerplatine

A-L1: Stromsensor

C-PV: Photovoltaikzähler / I: Photovoltaik-Wechselrichter  
(falls Photovoltaikanlage vorhanden ist)



4. Die CT-Box (Codes: PM02M, PM02T, PM02T100) kann auf einer DIN-Schiene befestigt werden, indem der entsprechende Haken gezogen und losgelassen wird (Abb. 5). Die kompakte CT-Box (Codes: PM03M, PM03T30, PM03T100) kann einfach frei im Schaltschrank abgelegt werden.

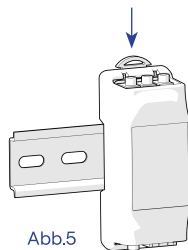


Abb.5

Für die Verbindung ist Folgendes erforderlich:

- Für **Dazebox C**, dargestellt in Abbildung 3a und 4a, muss das geschirmte Netzkabel durch ein Loch im Kabelverschraubungselement (PG) geführt werden, indem der Blindboden mit einem Schraubenzieher durchbrochen wird. Diese Kabelverschraubung hat zwei Blindlöcher Ø5 mm, eines ist für den Power Manager vorgesehen, das andere für das Bipolarkabel der Auslösespule (siehe Installationshandbuch Dazebox C).
- Für **Dazebox Home und Share T / S / TK / SK**, dargestellt in Abbildung 3b, 3c, 3d, 3e, 3f, 3g, 3h, 3i, 4b, 4c, 4d, 4e, 4f, 4g, 4h, 4i, führt das geschirmte Netzkabel durch ein Loch in der Kabeldurchführungsmembran (M).
- Für **Duo T / S**, dargestellt in Abbildung 3l und 4l, führt das geschirmte Netzkabel durch ein Loch in der Kabeldurchführungsmembran (M).
- Für **Urban T / S**, dargestellt in Abbildung 3m und 4m, führt das geschirmte Netzkabel durch ein Loch in der Kabeldurchführungsmembran (M).

**HINWEIS:** Für den ordnungsgemäßen Betrieb des Power Managers dürfen keine Verlängerungskabel für das Sensorkabel verwendet werden.

## Dazebox C

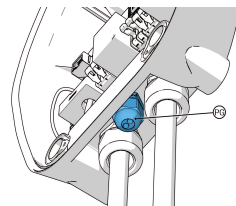


Abb. 3a

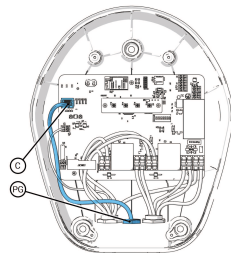


Abb. 4a

## Home T

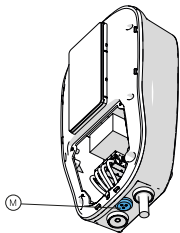


Abb. 3b

## Home S

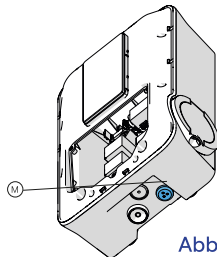


Abb. 3c

## Share T

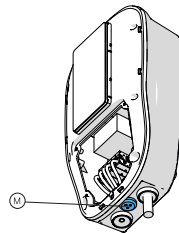


Abb. 3d

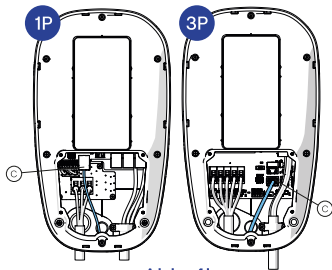


Abb. 4b

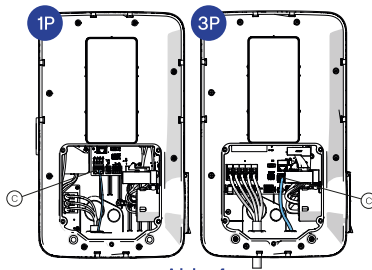


Abb. 4c

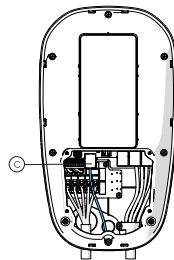


Abb. 4d

Share S

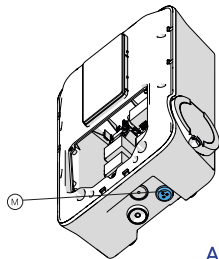


Abb. 3e

Home TK

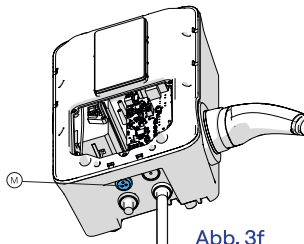


Abb. 3f

Home SK

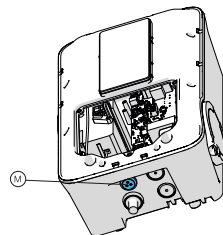


Abb. 3g

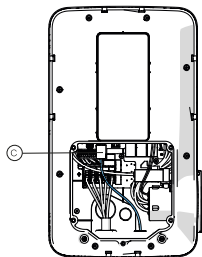


Abb. 4e

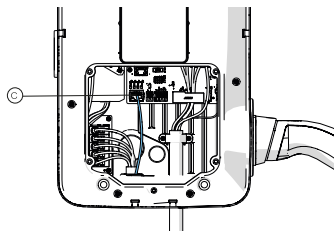


Fig. 4f

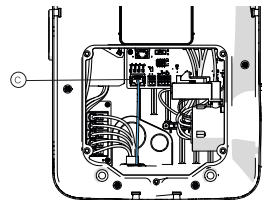


Abb. 4g

## Share TK

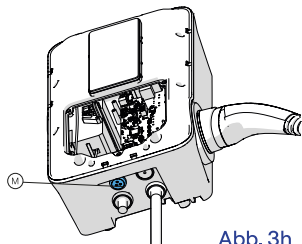


Abb. 3h

## Share SK

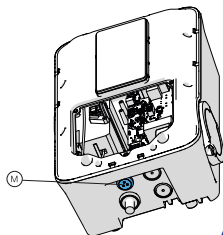


Abb. 3i

## Duo T/S

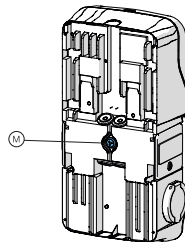


Abb. 3j

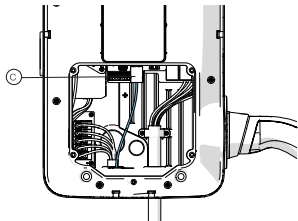


Abb. 4h

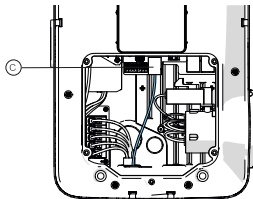


Abb. 4i

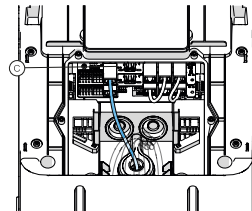


Abb. 4j

## Urban T/S

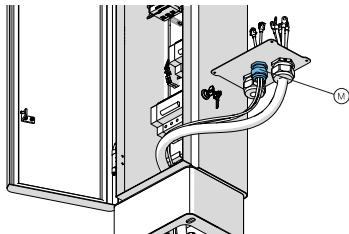


Abb. 3m

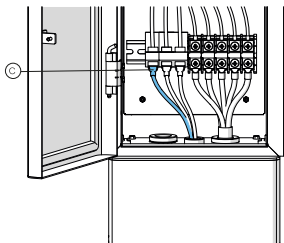
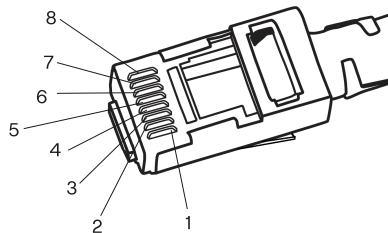


Abb. 4m

\* T-568B Konfigurationstabelle

Pin	T-568B
1	Weiß / Orange
2	Orange
3	Weiß / Grün
4	Blau
5	Weiß / Blau
6	Grün
7	Weiß / Braun
8	Braun



5. Der zweite RJ45, der in der Verpackung enthalten ist, muss am Ende des Netzkabels installiert werden.
6. Entfernen Sie 4 cm des Netzkabels und achten Sie darauf, das doppelte Schirmmaterial nicht zu entfernen. Entwirren und richten Sie die 8 Drähte aus und ordnen Sie sie gemäß dem Farbschema in der Tabelle (T-568B-Konfiguration)\*.
7. Setzen Sie den Knickschutz in das Kabel ein. Führen Sie die Drähte in der richtigen Reihenfolge in die vorgesehenen Kanäle des Steckverbinders ein und schieben Sie sie bis zum Ende, nahe dem Isoliermaterial.
8. Schneiden Sie die Drähte auf gleicher Höhe mit dem Ende des Steckverbinders ab.
9. Crimpen Sie den vorbereiteten RJ45-Stecker mit der entsprechenden Crimpzange.
10. Es ist wichtig, dass die Abschirmung des Kabels mit dem Metallteil des RJ45-Steckverbinders in Kontakt steht.
11. Überprüfen Sie die korrekte Verkabelung mit einem Netzkabel-Tester vor der Inbetriebnahme.
12. Verbinden Sie den neu montierten RJ45-Stecker mit dem RJ45-Anschluss links auf der Platine (C) der Ladestation (Abbildungen 4a, 4b, 4c, 4d, 4e, 4f, 4g, 4h, 4i, 4l und 4m).
13. Ziehen Sie die Kabelverschraubung (PG) fest, im Fall von Dazebox C (Abbildung 3a).



Die Abschirmung des Netzkabels muss mit dem Metallteil des RJ45-Steckverbinders in Kontakt stehen, damit eine Verbindung mit dem RJ45-Weibchenanschluss auf der Platine gewährleistet ist.

## 02.4 - Load Balancing zwischen mehreren Ladegeräten

Im Falle von Installationen mit mehreren Ladestationen unter einem einzigen Zähler, der nicht ausschließlich dem Ladenetzwerk gewidmet ist, ermöglicht die Installation des Power Managers auch die Funktion des dynamischen Lastmanagement zwischen mehreren Ladestationen. Durch ein Master/Slave-System werden die Ladestationen in der Lage sein, die verfügbare Leistung dynamisch zwischen den Fahrzeugen zu verteilen und sicherzustellen, dass der Gesamtverbrauch (Ladestationen + andere Lasten) unter dem gleichen Zähler das während der Netzwerkkonfiguration festgelegte Maximum nicht überschreitet.

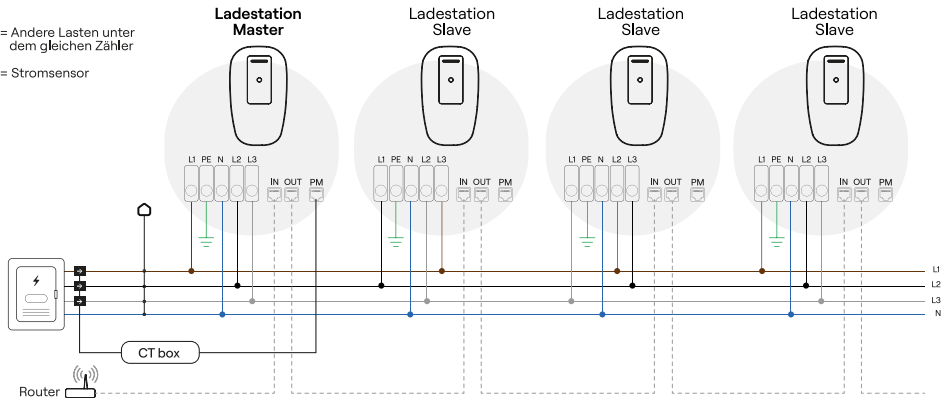
Die CT-Box muss nur mit der Master-Ladestation verbunden werden, das heißt mit der erste Ladestation, das dem Netzwerk hinzugefügt wird.

*Hinweis: Die Lastmanagement-Funktion ist auch mit einer WiFi-Verbindung kompatibel, jedoch wird für stabilere Leistungen die Verbindung über ein Ethernet-Kabel stark empfohlen.*

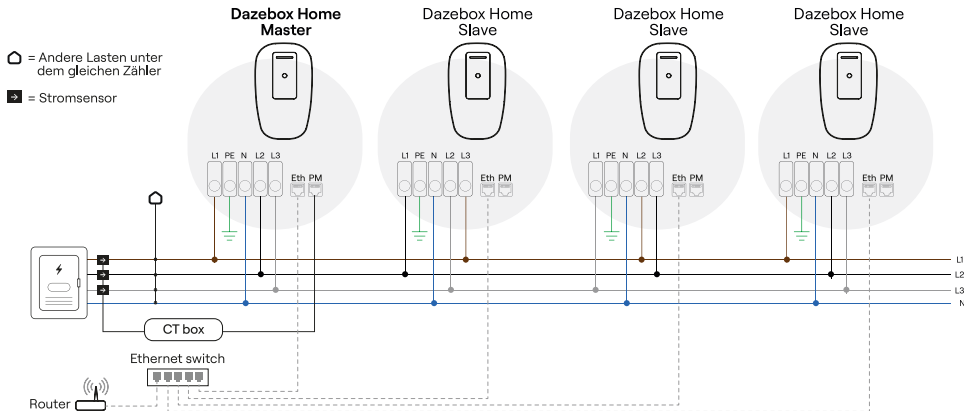
- Für **Dazebox Share, Duo und Urban**: Verbinden Sie die CT-Box mit dem Ethernet-Port (PM) und den Router mit dem Ethernet-Port (IN) des Masters (siehe Abbildung unten). Für die Slaves verbinden Sie den Ethernet-Ausgangsport (OUT) des Masters mit dem Eingangsport (IN) des ersten Slaves. Wiederholen Sie die OUT/IN-Verbindung zwischen den Slaves. Konsultieren Sie das Kapitel „Verkabelung“ im Installationshandbuch der Ladestation zur Identifizierung der Ports.

☐ = Andere Lasten unter dem gleichen Zähler

➔ = Stromsensor



- Für **Dazebox Home**: Verbinden Sie die CT-Box mit dem entsprechenden Ethernet-Port (PM) des Master-Ladegeräts. Sowohl der Master als auch der Slave müssen direkt über ihren eigenen Ethernet-Port (Eth) mit dem gleichen Router/Switch verbunden werden. Konsultieren Sie das Kapitel „Verkabelung“ im Installationshandbuch der Ladestation zur Identifizierung der Ports.



**HINWEIS:** Die Lastmanagement-Funktion ist sowohl mit einphasigen als auch mit dreiphasigen Anlagen kompatibel. Im Falle einer dreiphasigen Installation (bei der nur dreiphasige Ladestationen installiert werden müssen) ist es wichtig, die Phasen gleichmäßig im Verdrahtungssystem der verschiedenen Ladestationen zu verteilen, um eine Überlastung einer einzelnen Phase zu vermeiden (siehe Schaltpläne). Während der Konfiguration der Lastmanagement-Funktion über die App ist es erforderlich, die Phasenreihenfolge für jede einzelne Ladestation anzugeben.

# 01 - Descripción

El Power Manager es un dispositivo que permite modular dinámicamente la potencia dedicada a la carga del vehículo para no superar la potencia contratada del contador, evitando apagones causados por la carga. Existen dos versiones diferentes: el Power Manager para montaje en barra DIN (códigos: PM02M, PM02T, PM02T100 - Fig. 1A) y la versión compacta (códigos: PM03M, PM03T30, PM03T100) para instalaciones en espacios reducidos - Fig. 1B.

Dazebox C, Dazebox Home, Dazebox Share, Duo y Urban también pueden funcionar sin el Power Manager, cuya instalación no es obligatoria. Sin embargo, en ausencia del Power Manager, no se garantiza que se evite un apagón en caso de que se supere la potencia del contador establecida mediante la aplicación durante la fase de configuración de la red.

El Power Manager está compuesto por 2 elementos:

- Placa de control CT box de plástico
- Sensor de corriente en versión monofásica (PM02M PM03M) y trifásica de 30 kW (PM02T PM03T30) en la Fig. 1C, y sensor para la versión trifásica de 100 kW (PM02T100 PM03T100) en la Fig. 1D. Para las versiones Power Manager trifásicas se proporcionarán 3 sensores de corriente.

Fig. 1A

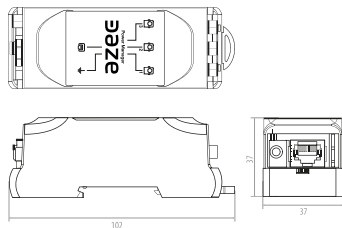


Fig. 1B

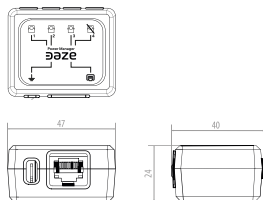


Fig. 1C

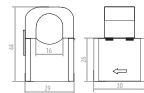
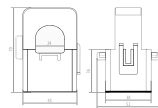


Fig. 1D



**Monofásico**

PM02M / PM03M

**Trifásico**PM02T / PM02T100  
PM03T30 / PM03T100

## Especificaciones generales

### 1 Productos compatibles

Dazebox C: DB07\*\*M\* / DB07\*\*T\* / DB07\*\*M\*\*\* / DB07\*\*T\*\*\*  
 Dazebox Home: DT01\*\*32\*\* / DS01\*\*32\*\* / DK01\*\*32\*\*P / DS01\*\*32\*\*P  
 Dazebox Share: DT02\*\*32\*\* / DS02\*\*32\*\* / DK01\*\*32\*\*P / DS01\*\*32\*\*P  
 Duo: OT01\*\*64\*\*\*\* / OS01\*\*64\*\*\*\*  
 Urban: UT01IT64T\*\*\*\* / US01IT64T\*\*\*\*

## Especificaciones eléctricas

2	Potencia máxima del contador	12,5 kW	37,5 kW / 100 kW *
3	Corriente máxima por fase	55 A	55 A / 145 A

\* El módulo Power Manager de 100 kW es compatible únicamente con Dazebox Home, Dazebox Share, Duo y Urban

## Instalación

4	Número de sensores de corriente	1	3
5	Sección máxima del cable de fase	Hasta 50 mm <sup>2</sup>	Hasta 50 mm <sup>2</sup> / Hasta 120 mm <sup>2</sup>
6	Cable de conexión al cargador (*no se garantiza que cables de categoría superior a Cat5e sean adecuados para los conectores RJ45 blindados proporcionados)	Cable de red CAT5e* blindado	
7	Blindaje del cable de red	F o S/FTP - SF/FTP - SF/UTP - F/UTP	
8	Longitud del cable de conexión del sensor de corriente - CT box	900 mm	
9	Conexión a la CT box	Jack 3,5 mm	
10	Longitud máxima del cable de red desde la CT box al cargador	170 m	
11	Montaje	Guía DIN o con tornillos (PM) / Libre (PM compacto)	

## 02 – Instalación



La conexión del sensor para la función de Load Balancing requiere la instalación por parte de un técnico profesional.  
**Nota: Sobre únicamente puede instalarse un Power Manager por contador. En instalaciones con varios cargadores, el Power Manager debe conectarse solo al primer cargador que se agregue a la red. Los demás se agregarán posteriormente a la red y se cablearán según el esquema del capítulo 2.4.**

### 02.1 – Contenido del paquete

En el paquete se incluye:

1. Sensor de corriente (1x versión monofásica y 3x para versión trifásica);
2. Tarjeta de control CT box;
3. Conectores RJ45 blindados con protección contra pliegues (2x).

### 02.2 – Preparación para la instalación

Necesario pero no incluido en el paquete:

- Cable de red para conectar la CT box al cargador.
- Conector Faston (hembra) y cable para la puesta a tierra.

## 02.3 - Montaje

1. Preparar la instalación de un cable de red del tipo indicado en la sección "Instalación" del capítulo "1" que conecte la CT Box al lugar de instalación del cargador.
2. El sensor de corriente (A) debe ser colocado en el cable de línea (L) que sale del contador principal (C) antes de cualquier bifurcación. Si se tiene un contador trifásico, colocar los tres sensores en L1, L2 y L3, respectivamente. Consultar los esquemas de conexión en las páginas 22-23 para colocar el sensor en la dirección correcta. Una colocación incorrecta puede causar fallos en el funcionamiento.
3. El sensor de corriente tiene un conector jack (J) para la conexión con la placa CT box (B). En la placa también hay una entrada RJ45 para conectar, mediante un cable de red Cat5e blindado, la CT box al sistema de carga. Los conectores RJ45 para cablear ambos extremos del cable están incluidos. Las instrucciones de crimpado se proporcionan desde el punto 5 hasta el punto 12, en las páginas siguientes. Realizar la puesta a tierra mediante conector Faston (como se indica en la Fig. 2).

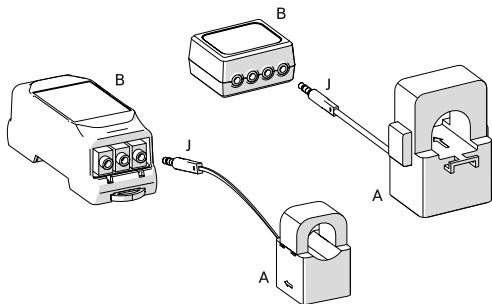
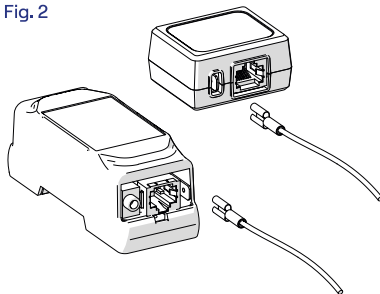


Fig. 2



## 1. Esquema de conexión de PM02M en una instalación monofásica

C: contador

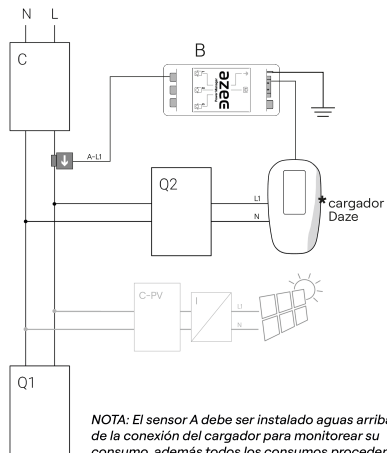
Q1, Q2, ...: armarios eléctricos

B: tarjeta CT box

A-L1: sensor de corriente

C-PV: contador fotovoltaico / I: inversor fotovoltaico

(si existe sistema fotovoltaico)



## 2. Esquema de conexión de PM02T/PM02T100 en una instalación trifásica

C: contador

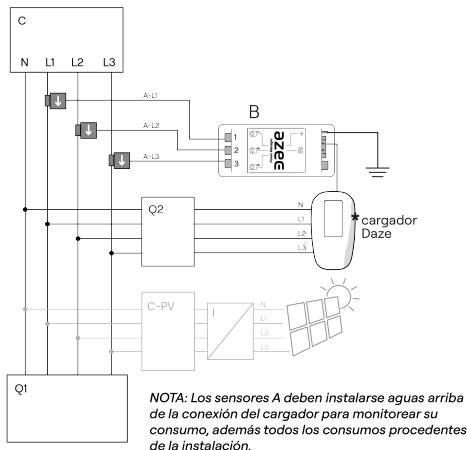
Q1, Q2, ...: armarios eléctricos

B: tarjeta CT box

A-L1 / L2 / L3: sensor de corriente

C-PV: contador fotovoltaico / I: inversor fotovoltaico

(si existe sistema fotovoltaico)



### 3. Esquema de conexión de PM03M en una instalación monofásica

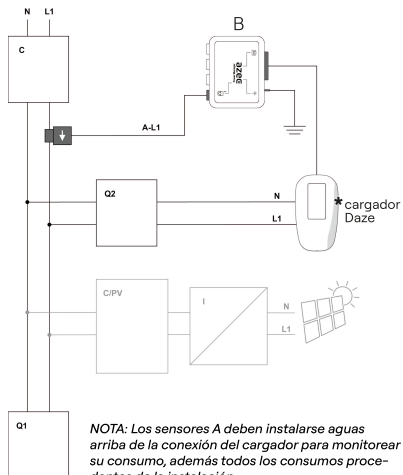
C: contador

Q1, Q2, ...: armarios eléctricos

B: tarjeta CT box

A-L1 / L2 / L3: sensor de corriente

C-PV: contador fotovoltaico / I: inversor fotovoltaico  
(si sistema fotovoltaico presente)



### 4. Esquema de conexión de PM03T30/PM03T100 en una instalación trifásica

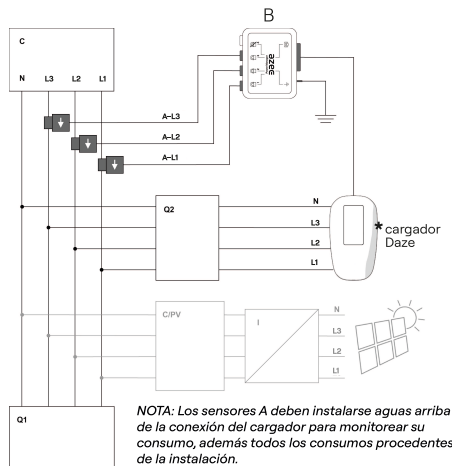
C: contador

Q1, Q2, ...: armarios eléctricos

B: tarjeta CT box

A-L1: sensor de corriente

C-PV: contador fotovoltaico / I: inversor fotovoltaico  
(si sistema fotovoltaico presente)



4. La CT box (códigos: PM02M, PM02T, PM02T100) se puede fijar a un rail DIN, bloqueándola tirando y soltando el enganche correspondiente (Fig. 5). La CT box compacta (códigos: PM03M, PM03T30, PM03T100) se puede colocar libremente dentro del cuadro eléctrico.

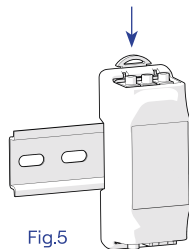


Fig.5

Para la conexión es necesario:

- Para **Dazebox C**, representado en la Figura 3a y 4a, el cable de red blindado debe pasar a través de un agujero en el prensaestopas (PG), rompiendo el fondo ciego con un destornillador. Este prensaestopas tiene dos agujeros ciegos de Ø5 mm, uno está destinado al Power Manager y el otro para el cable bipolar de la bobina de desconexión (consultar el Manual de instalación de Dazebox C).
- Para **Dazebox Home y Share T / S / TK / SK**, representado en las Figuras 3b, 3c, 3d, 3e, 3f, 3g, 3h, 3i, 4b, 4c, 4d, 4e, 4f, 4g, 4h, 4i, el cable de red blindado pasa a través de un agujero en la membrana del prensaestopas (M).
- Para **Duo T / S**, representado en las Figuras 3l y 4l, el cable de red blindado pasa a través de un agujero en la membrana del prensaestopas (M).
- Para **Urban T / S**, representado en las Figuras 3m y 4m, el cable de red blindado pasa a través de un agujero en la membrana del prensaestopas (M).

**NOTA:** Para el correcto funcionamiento del Power Manager, no se pueden utilizar extensiones para el cable del sensor.

## Dazebox C

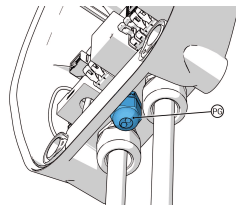


Fig. 3a

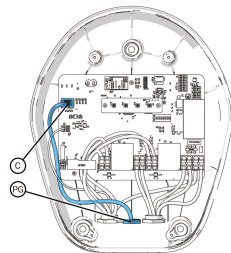


Fig. 4a

## Home T

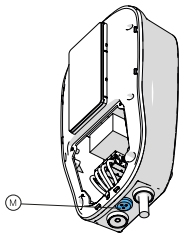


Fig. 3b

## Home S

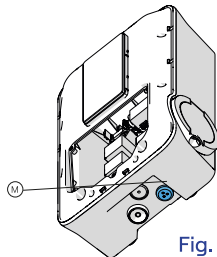


Fig. 3c

## Share T

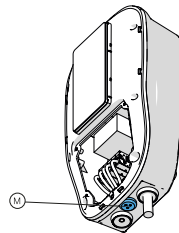


Fig. 3d

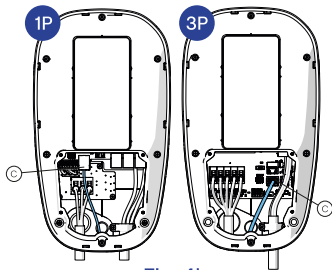


Fig. 4b

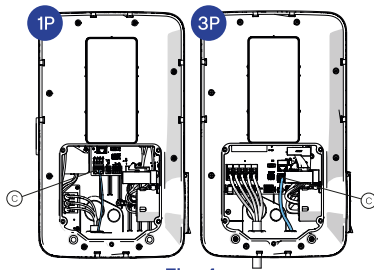


Fig. 4c

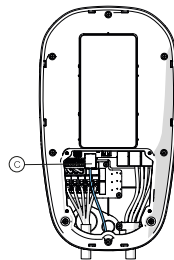


Fig. 4d

Share S

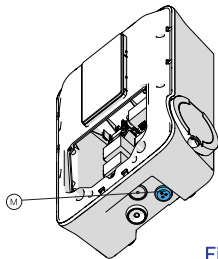


Fig. 3e

Home TK

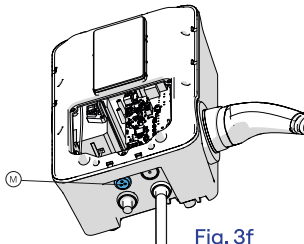


Fig. 3f

Home SK

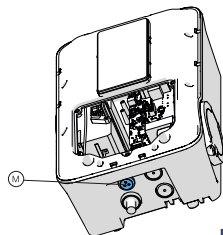


Fig. 3g

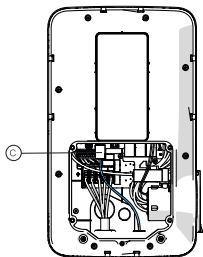


Fig. 4e

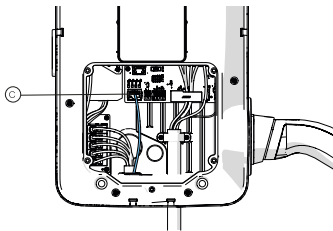


Fig. 4f

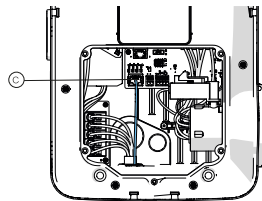


Fig. 4g

## Share TK

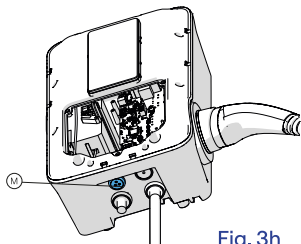


Fig. 3h

## Share SK

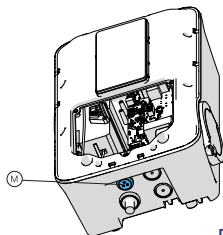


Fig. 3i

## Duo T/S

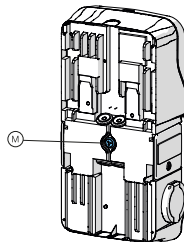


Fig. 3l

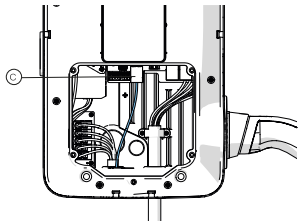


Fig. 4h

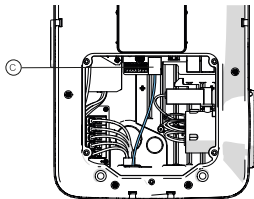


Fig. 4i

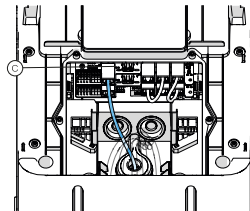


Fig. 4l

## Urban T/S

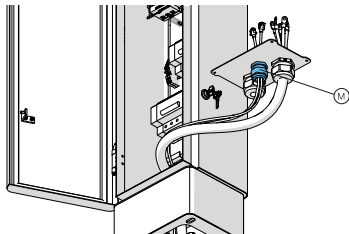


Fig. 3m

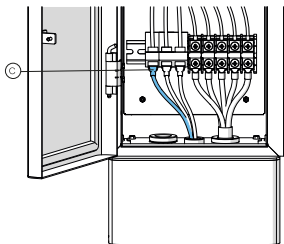
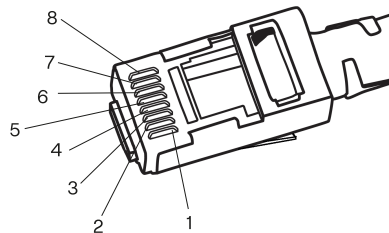


Fig. 4m

\* Tabla de configuración T-568B

Pin	T-568B
1	Blanco / Naranja
2	Naranja
3	Blanco / Verde
4	Azul
5	Blanco / Azul
6	Verde
7	Blanco / Marrón
8	Marrón



5. El segundo RJ45 proporcionado en el paquete debe instalarse en el extremo del cable de red.
6. Pelar 4 cm de cable de red, teniendo cuidado de no quitar el doble blindaje. Desenredar y alinear los 8 cables y organizarlos según el esquema de colores indicado en la tabla (configuración T-568B).
7. Insertar la protección contra pliegues en el cable. Introducir los cables en el orden correcto en los canales del conector y deslizarlos hasta el fondo, cerca del aislamiento.
8. Cortar los cables al ras del extremo del conector.
9. Crimpar el conector RJ45 preparado con la herramienta de crimpar adecuada.
10. Es importante que el blindaje del cable esté en contacto con la parte metálica del conector RJ45.
11. Verificar el cableado correcto con un comprobador de cables de red antes de ponerlo en funcionamiento.
12. Conectar el terminal RJ45 recién montado al puerto RJ45 a la izquierda de la tarjeta (C) del cargador (Figuras 4a, 4b, 4c, 4d, 4e, 4f, 4g, 4h, 4i, 4l y 4m).
13. Ajustar el prensaestopas (PG), en el caso de **Dazebox C** (Figura 3a).



El blindaje del cable de red debe estar en contacto con la parte metálica del conector RJ45 para asegurar la continuidad con el conector RJ45 hembra ubicado en la placa.

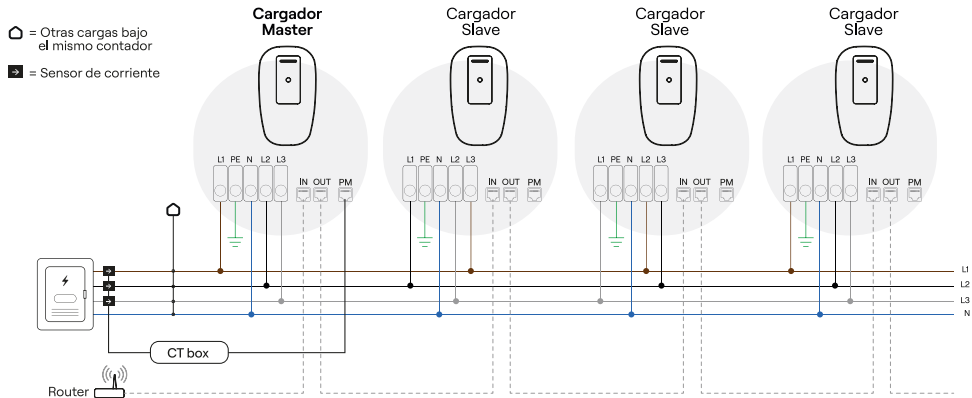
## 02.4 - Load Balancing entre varios cargadores

En el caso de instalaciones con varios cargadores bajo un único contador que no está exclusivamente dedicado a la red de cargadores, la instalación del Power Manager también habilita la funcionalidad de Load Balancing entre varios cargadores con gestión dinámica de la carga: a través de un sistema Master/Slave, los cargadores podrán distribuir dinámicamente la potencia disponible entre los vehículos en carga, asegurándose de que el consumo total (cargadores + otras cargas bajo el mismo contador) no supere el límite máximo establecido durante la configuración de la red.

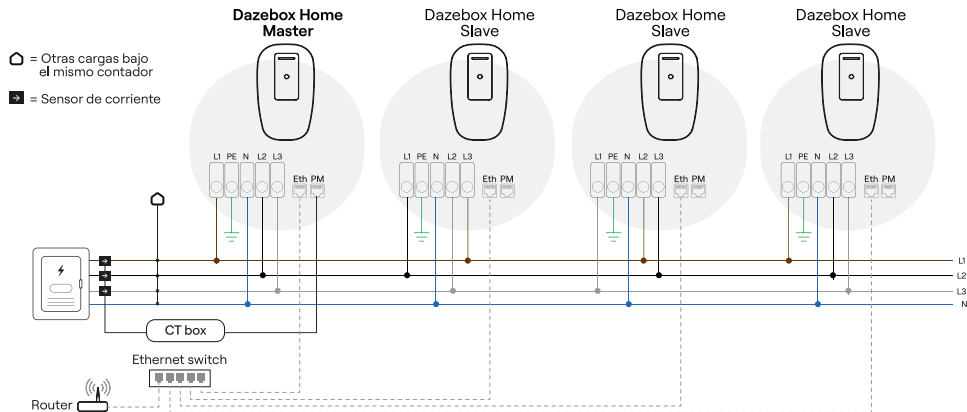
La CT box debe conectarse únicamente al cargador Master, es decir, al primer cargador agregado a la red.

*Nota: La funcionalidad Load Balancing también es compatible con una conexión WiFi; sin embargo, para un rendimiento más estable, se recomienda encarecidamente la conexión mediante cable Ethernet.*

- Para Dazebox Share, Duo y Urban: conectar la CT box al puerto Ethernet (PM) y el router al puerto Ethernet (IN) del Master (ver figura abajo). Para los Slaves, conectar el puerto Ethernet de salida (OUT) del Master al puerto de entrada (IN) del primer Slave. Repetir la conexión OUT/IN entre los Slaves. Consultar el capítulo "Conexiones" del manual de instalación del cargador para la identificación de los puertos.



- **Para Dazebox Home:** conectar la CT box al puerto Ethernet (PM) del cargador Master. Tanto el Master como el Slave deben estar conectados directamente al mismo router/switch a través de su propio puerto Ethernet (Eth). Consultar el capítulo "Conexiones" del manual de instalación del cargador para la identificación de los puertos.



NOTA: La funcionalidad de Load Balancing es compatible tanto con instalaciones monofásicas como trifásicas. En el caso de una instalación trifásica (donde solo se deben instalar cargadores trifásicos), es importante distribuir de manera equitativa las fases en el cableado de los diferentes cargadores para evitar sobrecargar una sola fase (ver los esquemas). Durante la configuración de la funcionalidad de Load Balancing a través de la aplicación, se requiere especificar el orden de las fases en cada cargador.

# 01 – Descrição

O Power Manager é um dispositivo que permite modular dinamicamente a potência dedicada ao carregamento do veículo para não ultrapassar a potência contratada do contador, evitando apagões causados pelo carregamento. Existem duas versões diferentes: o Power Manager para montagem em barra DIN (códigos: PM02M, PM02T, PM02T100 - Fig. 1A) e a versão compacta (códigos: PM03M, PM03T30, PM03T100) para instalações em espaços reduzidos - Fig. 1B

Dazebox C, Dazebox Home, Dazebox Share, Duo e Urban também podem funcionar sem o Power Manager, cuja instalação não é obrigatória. No entanto, na ausência do Power Manager, não se garante que um apagão seja evitado caso a potência do contador estabelecida através da aplicação seja ultrapassada durante a fase de configuração da rede.

O Power Manager é composto por 2 elementos:

- Placa de controle CT box de plástico
- Sensor de corrente na versão monofásica (PM02M PM03M) e trifásica de 30 kW (PM02T PM03T30) na Fig. 1C, e sensor para a versão trifásica de 100 kW (PM02T100 PM03T100) na Fig. 1D. Para as versões Power Manager trifásicas serão fornecidos 3 sensores de corrente.

Fig. 1A

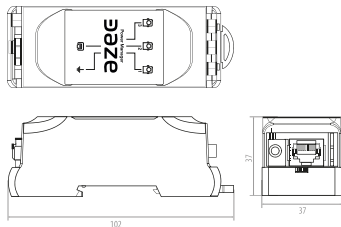


Fig. 1B

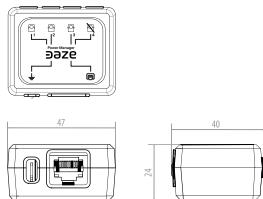


Fig. 1C

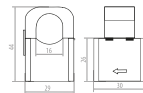
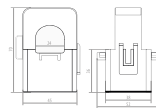


Fig. 1D



**Monofásico**

PM02M / PM03M

**Trifásico**PM02T / PM02T100  
PM03T30 / PM03T100

## Especificações gerais

### 1 Produtos compatíveis

Dazebox C: DB07\*\*M\* / DB07\*\*T\* / DB07\*\*M\*\*\* / DB07\*\*T\*\*\*  
 Dazebox Home: DT01\*\*32\*\* / DS01\*\*32\*\* / DK01\*\*32\*\*P / DS01\*\*32\*\*P  
 Dazebox Share: DT02\*\*32\*\* / DS02\*\*32\*\* / DK01\*\*32\*\*P / DS01\*\*32\*\*P  
 Duo: OT01\*\*64\*\*\*\* / OS01\*\*64\*\*\*\*  
 Urban: UT01IT64T\*\*\*\* / US01IT64T\*\*\*\*

## Especificações elétricas

2	Potência máxima do contador	12,5 kW	37,5 kW / 100 kW *
3	Corrente máxima por fase	55 A	55 A / 145 A

\* O Módulo Power Manager de 100 kW é compatível apenas com Dazebox Home, Dazebox Share, Duo e Urban

## Instalação

4	Número de sensores de corrente	1	3
5	Máxima seção do cabo de fase	Até 50 mm <sup>2</sup>	Até 50 mm <sup>2</sup> / Até 120 mm <sup>2</sup>
6	Cabo de conexão ao carregador (*não se garante que cabos de categoria superior a Cat5e sejam adequados aos conectores RJ45 blindados fornecidos)	Cabo de rede CAT5e* blindado	
7	Blindagem do cabo de rede	F o S/FTP - SF/FTP - SF/UTP - F/UTP	
8	Comprimento do cabo de conexão do sensor de corrente - CT box	900 mm	
9	Conexão à CT box	Jack 3,5 mm	
10	Comprimento máximo do cabo de rede da CT box ao carregador	170 m	
11	Montagem	Guia DIN ou com parafusos (PM) / Livre (PM compacto)	

## 02 – Instalação



A conexão do sensor para a função de Load Balancing requer a instalação por um técnico profissional.

**Nota Bene:** sobre um contador, é possível instalar apenas um Power Manager. Em instalações com múltiplos carregadores, o Power Manager deve ser conectado apenas ao primeiro carregador a ser adicionado à rede, os restantes devem ser adicionados posteriormente à rede e cabeados de acordo com o esquema do capítulo 2.4.

### 02.1 – Conteúdo da embalagem

Na embalagem são fornecidos:

1. Sensor de corrente (1x versão monofásica e 3x para versão trifásica);
2. Placa de controle CT box;
3. Conectores RJ45 blindados com proteção anti-curve (2x).

### 02.2 – Preparação para a instalação

Necessário, mas não incluído na embalagem:

- Cabo de rede para conexão da CT box ao carregador.
- Conector Faston (fêmea) e cabo para aterramento.

## 02.3 – Montagem

1. Preparar a instalação de um cabo de rede do tipo indicado na seção “Instalação” do capítulo “1”, conectando a CT Box ao local de instalação do carregador.
2. O sensor de corrente (A) deve ser posicionado no cabo de linha (L) que sai do contador geral (C), antes de qualquer ramificação. Se for um contador trifásico, posicione os três sensores respectivamente em L1, L2, L3. Consulte os esquemas de conexão nas páginas 22-23 para posicionar o sensor na direção correta. Um posicionamento incorreto pode causar falhas no funcionamento.
3. O sensor de corrente possui um conector jack (J) para conexão com a placa CT box (B). Na placa, também há uma entrada RJ45 para conectar, através de cabo de rede cat5e blindado, a CT box ao sistema de carregamento. Os conectores RJ45 para crimpar as extremidades do cabo estão incluídos. As instruções de crimpeza são fornecidas nos pontos 5 a 12 das páginas seguintes. Realizar a aterragem através do conector Faston (como indicado na Fig. 2).

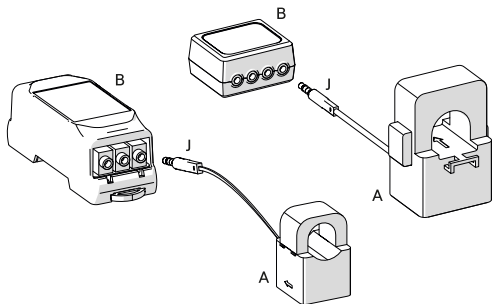
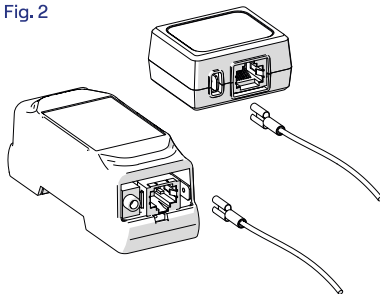


Fig. 2



## 1. Esquema de conexão do PM02M em instalação monofásica

C: contador

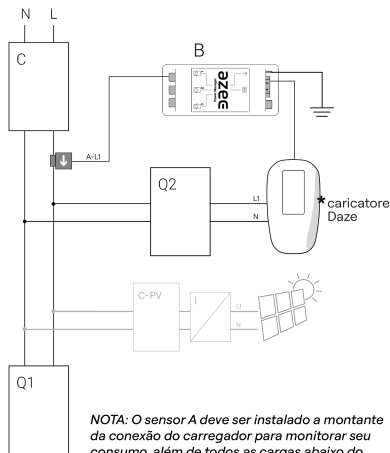
Q1, Q2, ...: quadros elétricos

B: placa CT box

A-L1: sensor de corrente

C-PV: contador fotovoltaico / I: inversor fotovoltaico

(se fotovoltaico presente)



**NOTA:** O sensor A deve ser instalado a montante da conexão do carregador para monitorar seu consumo, além de todas as cargas abaixo do contador.

## 2. Esquema de conexão do PM02T/PM02T100 em instalação trifásica

C: contador

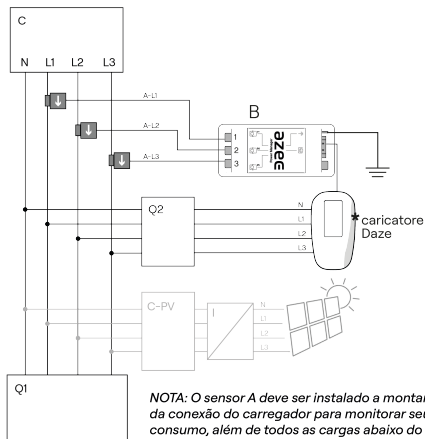
Q1, Q2, ...: quadros elétricos

B: placa CT box

A-L1 / L2 / L3: sensor de corrente

C-PV: contador fotovoltaico / I: inversor fotovoltaico

(se fotovoltaico presente)



**NOTA:** O sensor A deve ser instalado a montante da conexão do carregador para monitorar seu consumo, além de todas as cargas abaixo do contador.

### 3. Esquema de conexão do PM03M em instalação monofásica.

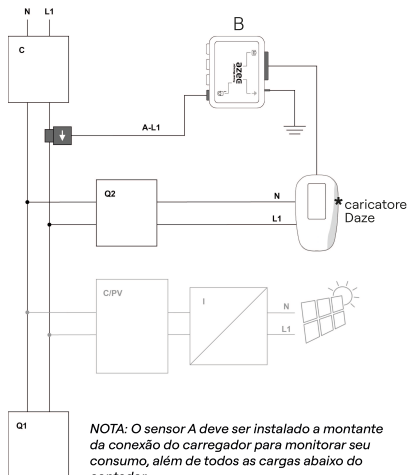
C: contador

Q1, Q2, ...: quadros elétricos

B: placa CT box

A-L1 / L2 / L3: sensor de corrente

C-PV: contador fotovoltaico / I: inversor fotovoltaico  
(se fotovoltaico presente)



### Esquema de conexão do PM03T30/PM03T100 em instalação trifásica.

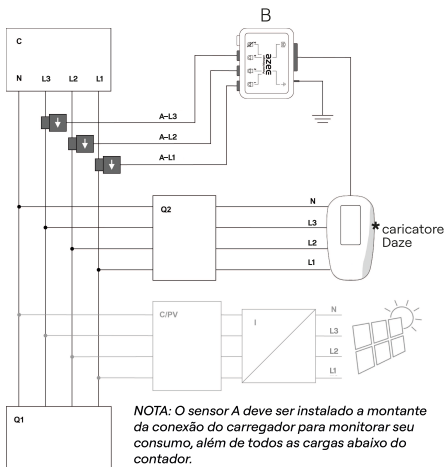
C: contador

Q1, Q2, ...: quadros elétricos

B: placa CT box

A-L1: sensor de corrente

C-PV: contador fotovoltaico / I: inversor fotovoltaico  
(se fotovoltaico presente)



4. A CT box (códigos: PM02M, PM02T, PM02T100) pode ser fixada em guia DIN, travada puxando e soltando o gancho apropriado (Fig. 5). A CT box compacta (códigos: PM03M, PM03T30, PM03T100) pode ser simplesmente colocada livremente dentro do quadro elétrico.

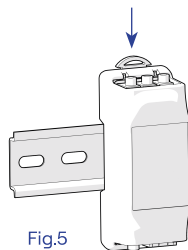


Fig.5

Para a conexão, é necessário:

- para **Dazebox C**, representado nas Figuras 3a e 4a, o cabo de rede blindado deve passar através de um furo do prensa-cabo (PG), rompendo o fundo cego com uma chave de fenda. Este prensa-cabo tem dois furos cegos Ø5 mm, um é destinado ao Power Manager, o outro ao cabo bipolar da bobina de desengate (consultar o Manual de instalação Dazebox C).

- para **Dazebox Home e Share T / S / TK / SK**, representado nas Figuras 3b, 3c, 3d, 3e, 3f, 3g, 3h, 3i, 4b, 4c, 4d, 4e, 4f, 4g, 4h, 4i, o cabo de rede blindado passa através de um furo na membrana do prensa-cabo (M).

- para **Duo T / S**, representado nas Figuras 3l, 4l, o cabo de rede blindado passa através de um furo na membrana do prensa-cabo (M).

- para **Urban T / S**, representado nas Figuras 3m, 4m, o cabo de rede blindado passa através de um furo na membrana do prensa-cabo (M).

**NOTA:** Para o correto funcionamento do Power Manager, não é possível utilizar extensões para o cabo do sensor.

## Dazebox C

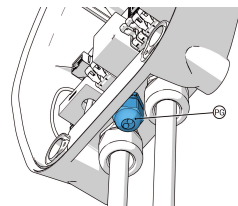


Fig. 3a

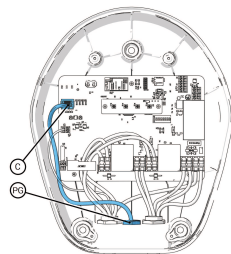


Fig. 4a

## Home T

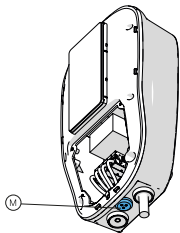


Fig. 3b

## Home S

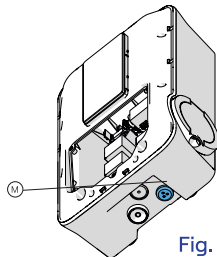


Fig. 3c

## Share T

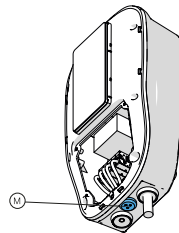


Fig. 3d

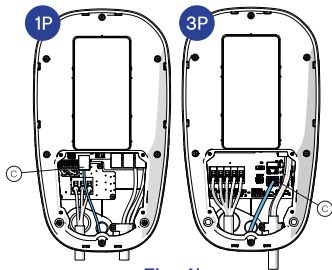


Fig. 4b

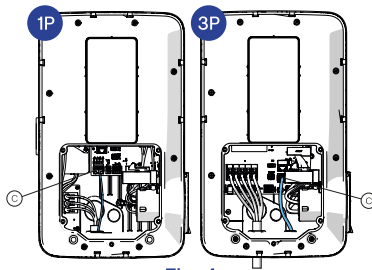


Fig. 4c

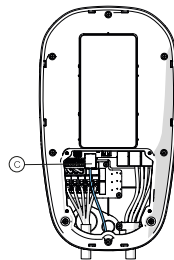


Fig. 4d

Share S

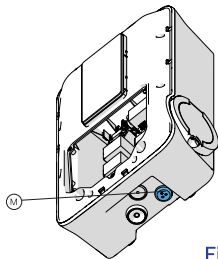


Fig. 3e

Home TK

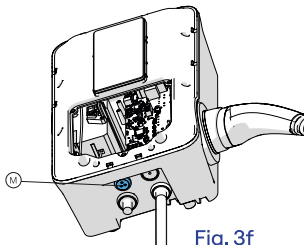


Fig. 3f

Home SK

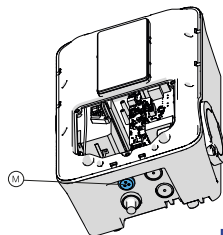


Fig. 3g

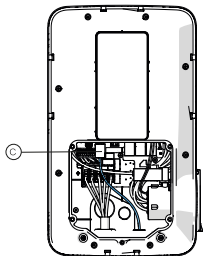


Fig. 4e

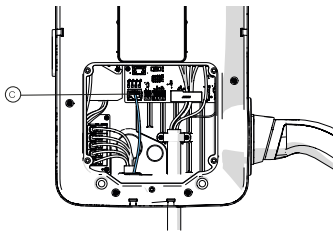


Fig. 4f

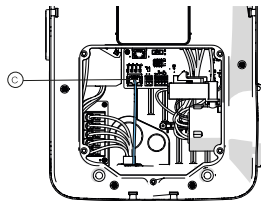


Fig. 4g

## Share TK

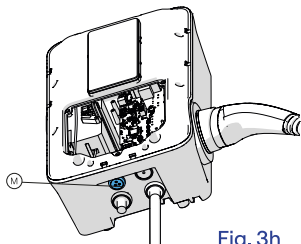


Fig. 3h

## Share SK

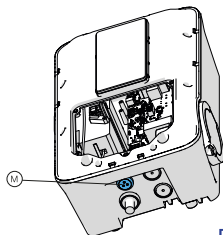


Fig. 3i

## Duo T/S

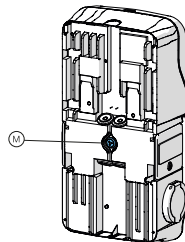


Fig. 3l

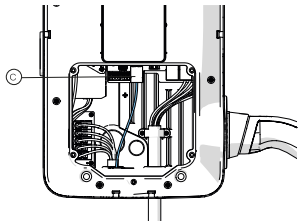


Fig. 4h

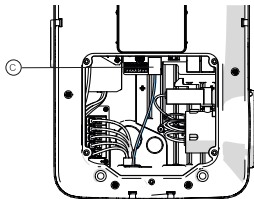


Fig. 4i

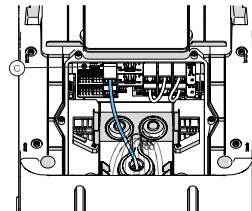


Fig. 4l

## Urban T/S

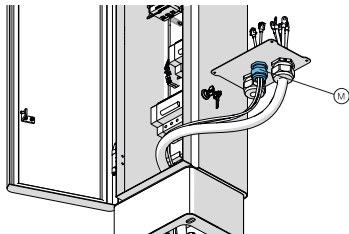


Fig. 3m

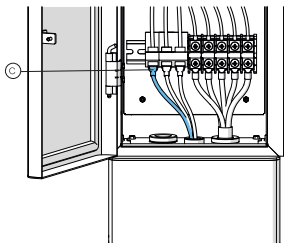
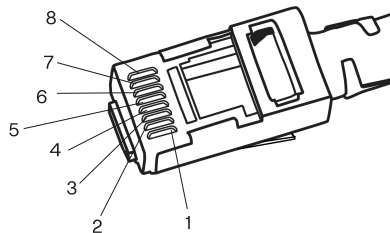


Fig. 4m

\* Tabela de configuração T-568B

Pin	T-568B
1	Branco / Laranja
2	Laranja
3	Branco / Verde
4	Azul
5	Branco / Azul
6	Verde
7	Branco / Castanho
8	Castanho



5. O segundo RJ45 fornecido na embalagem deve ser instalado na extremidade do cabo de rede.
6. Desencapar 4 cm do cabo de rede, tomando cuidado para não remover a dupla blindagem. Desfiar e endireitar os 8 fios e organizá-los de acordo com o esquema de cores apresentado na tabela (configuração T-568B) \*
7. Inserir a proteção anti-curve no cabo. Colocar os fios na ordem nos canais apropriados do conector e deslizar até o final, próximo ao isolante.
8. Cortar os fios nivelados à extremidade do conector.
9. Crimpar o conector RJ45 assim preparado com o alicate apropriado.
10. É importante que a blindagem do cabo esteja em contato com a parte metálica do conector RJ45.
11. Verificar a fiação correta com um testador de cabo de rede antes de colocar em funcionamento.
12. Conectar o terminal RJ45 recém-montado à porta RJ45 à esquerda da placa (C) do carregador (Figura 4a, 4b, 4c, 4d, 4e, 4f, 4g, 4h, 4i, 4l e 4m).
13. Aperte o prensa-cabo (PG), no caso de Dazebox C (Figura 3a).



A blindagem do cabo de rede deve estar em contato com a parte metálica do conector RJ45 para garantir continuidade com o conector RJ45 fêmea localizado na placa.

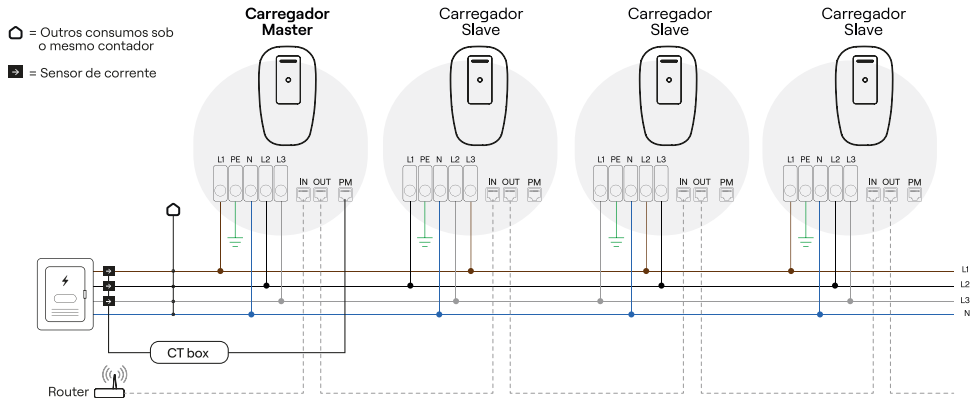
## 02.4 - Balanceamento de Carga entre vários carregadores

Para instalações com mais de um carregador sob um único contador, não dedicado exclusivamente à rede de carregadores, a instalação do Power Manager também habilita a funcionalidade de Balanceamento de Carga entre os carregadores com gerenciamento dinâmico da carga: através de um sistema Master/Slave, os carregadores serão capazes de distribuir dinamicamente a potência disponível entre os veículos em carga, garantindo que o consumo total (carregadores + outros carregamentos sob o mesmo contador) não ultrapasse o limite máximo definido durante a configuração da rede.

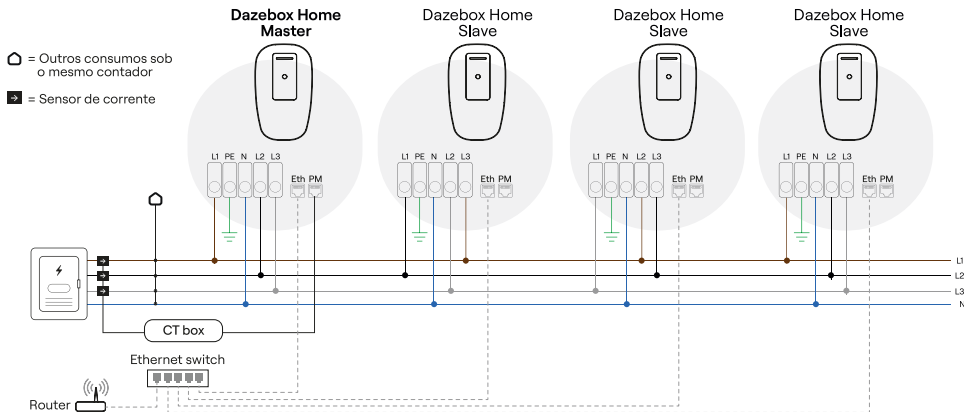
A CT box deve ser conectada apenas ao carregador Master, ou seja, o primeiro carregador adicionado à rede.

*Nota: a funcionalidade de Balanceamento de Carga também é compatível com uma conexão WiFi, no entanto, para um desempenho mais estável, é altamente recomendada a conexão via cabo Ethernet.*

- Para Dazebox Share, Duo e Urban: conecte a CT box à porta Ethernet (PM) e o roteador à porta Ethernet (IN) do Master (veja a figura abaixo). Para os Slaves, conecte a porta Ethernet de saída (OUT) do Master à porta de entrada (IN) do primeiro Slave. Repita a conexão OUT/IN entre os Slaves. Consulte o capítulo "Conexões" do manual de instalação do carregador para a identificação das portas.



- **Para Dazebox Home:** conecte a CT box à porta Ethernet (PM) do carregador master. Tanto o Master quanto o Slave devem ser conectados diretamente ao mesmo roteador/switch através de sua própria porta Ethernet (Eth). Consulte o capítulo "Conexões" do manual do carregador para a identificação das portas.



**NOTA BENE:** A funcionalidade de Balanceamento de Carga é compatível tanto com instalações monofásicas quanto trifásicas. No caso de uma instalação trifásica (onde apenas carregadores trifásicos devem ser instalados), é importante distribuir igualmente as fases no cabeamento dos diferentes carregadores, a fim de evitar sobrecarga em uma única fase (consulte os esquemas). Durante a configuração via App da funcionalidade de Balanceamento de Carga, é necessário informar a ordem das fases em cada carregador.

# daze

[daze.eu](https://daze.eu)

**Daze HQ**

Bergamo, Italy  
+39 035 1983 1355  
[info@daze.eu](mailto:info@daze.eu)

**Daze HQ**

Milano, Italy  
+39 035 1983 1355  
[info@daze.eu](mailto:info@daze.eu)

**Daze Ibérica**

Madrid Spain  
+34 911 47 60 74  
[contacto@daze.eu](mailto:contacto@daze.eu)

**Daze France**

+33 07 44 73 28 41  
[service@daze.eu](mailto:service@daze.eu)